

# A FEW WORDS ABOUT SAFETY

## SERVICE INFORMATION

The service and repair information contained in this manual is intended for use by qualified, professional technicians. Attempting service or repairs without the proper training, tools, and equipment could cause injury to you and/or others. It could also damage the engine or create an unsafe condition.

This manual describes the proper methods and procedures for performing service, maintenance, and repairs. Some procedures require the use of special tools. Any person who intends to use a replacement part, service procedure, or a tool that is not recommended by Honda, must determine the risks to their personal safety and the safe operation of the engine.

If you need to replace a part, use genuine Honda parts with the correct part number, or an equivalent part. We strongly recommend that you do not use replacement parts of inferior quality.

### For Your Customer's Safety

Proper service and maintenance are essential to the customer's safety and the reliability of the engine. Any error or oversight while servicing an engine can result in faulty operation, damage to the engine, or injury to others.

### For Your Safety

Because this manual is intended for the professional service technician, we do not provide warnings about many basic shop safety practices (e. g., Hot parts – wear gloves). If you have not received shop safety training or do not feel confident about your knowledge of safe servicing practices, we recommend that you do not attempt to perform the procedures described in this manual.

Some of the most important general service safety precautions are given below. However, we cannot warn you of every conceivable hazard that can arise in performing service and repair procedures. Only you can decide whether or not you should perform a given task.

### Important Safety Precautions

- Make sure you have a clear understanding of all basic shop safety practices and that you are wearing appropriate clothing and using safety equipment. When performing any service task, be especially careful of the following:
  - Read all of the instructions before you begin, and make sure you have the tools, the replacement or repair parts, and the skills required to perform the tasks safely and completely.
  - Protect your eyes by using proper safety glasses, goggles, or face shields any time you hammer, drill, grind, or work around pressurized air or liquids, and springs or other stored-energy components. If there is any doubt, put on eye protection.
  - Use other protective wear when necessary, for example, gloves or safety shoes. Handling hot or sharp parts can cause severe burns or cuts. Before you grab something that looks like it can hurt you, stop and put on gloves.
- Make sure the engine is off before you begin any servicing procedures, unless the instruction tells you to do otherwise. This will help eliminate several potential hazards:
  - Carbon monoxide poisoning from engine exhaust. Be sure there is adequate ventilation whenever you run the engine.
  - Burns from hot parts. Let the engine and exhaust system cool before working in those areas.
  - Injury from moving parts. If the instruction tells you to run the engine, be sure your hands, fingers, and clothing are out of the way.
- Gasoline vapors are explosive. To reduce the possibility of a fire or explosion, be careful when working around gasoline.
  - Use only a nonflammable solvent, not gasoline, to clean parts.
  - Never drain or store gasoline in an open container.
  - Keep all cigarettes, sparks, and flames away from all fuel-related parts.

### WARNING

Improper service or repairs can create an unsafe condition that can cause your customer or others to be seriously hurt or killed.

Follow the procedures and precautions in this manual and other service materials carefully.

### WARNING

Failure to properly follow instructions and precautions can cause you to be seriously hurt or killed.

Follow the procedures and precautions in this manual carefully.

## INTRODUCTION

This manual covers service and repair procedures for the Honda GX35 engine.

All information contained in this manual is based on the latest product information available at the time of printing. We reserve the right to make changes at anytime without notice.

No part of this publication may be reproduced, stored in a retrieval system, or transmitted, in any form, by any means, electronic, mechanical, photocopying, recording, or otherwise, without prior written permission of the publisher. This includes text, figures, and tables.

As you read this manual, you will find information that is preceded by a **NOTICE** symbol. The purpose of this message is to help prevent damage to the engine, other property, or the environment.

### SAFETY MESSAGES

Your safety, and the safety of others, are very important. To help you make informed decisions, we have provided safety messages and other safety information throughout this manual. Of course, it is not practical or possible to warn you about all the hazards associated with servicing this engine. You must use your own good judgment.

You will find important safety information in a variety of forms, including:

- **Safety messages** — preceded by a safety alert symbol  and one of three signal words, DANGER, WARNING, or CAUTION.

These signal words mean:

** DANGER** You WILL be KILLED or SERIOUSLY HURT if you don't follow instructions.

** WARNING** You CAN be KILLED or SERIOUSLY HURT if you don't follow instructions.

** CAUTION** You CAN be HURT if you don't follow instructions.

- **Instructions** — how to service this engine correctly and safely.

**Honda Motor Co., Ltd.  
Service Publications Office**

## CONTENTS

<b>SPECIFICATIONS</b>	<b>1</b>
<b>SERVICE INFORMATION</b>	<b>2</b>
<b>MAINTENANCE</b>	<b>3</b>
<b>TOP COVER/MUFFLER</b>	<b>4</b>
<b>AIR CLEANER/CARBURETOR</b>	<b>5</b>
<b>RECOIL STARTER/FUEL TANK</b>	<b>6</b>
<b>STARTER PULLEY/IGNITION COIL/ CLUTCH SHOE/FLYWHEEL</b>	<b>7</b>
<b>CAM PULLEY/CYLINDER HEAD COVER/ LOWER CRANKCASE</b>	<b>8</b>
<b>CRANKSHAFT/PISTON/CYLINDER BLOCK/VALVES</b>	<b>9</b>
<b>INDEX</b>	<b>10</b>
<b>SUPPLEMENT FOR NT TYPE</b>	<b>11</b>

<b>1. SPECIFICATIONS</b>	<b>3. DIMENSIONAL DRAWINGS</b>
<b>2. PERFORMANCE CURVES</b>	<b>4. WIRING DIAGRAM</b>

**1. SPECIFICATIONS**

• **DIMENSIONS AND WEIGHTS**

Model	GX35	
Type	SA2	SAT
Overall length	204 mm (8.0 in)	
Overall width	234 mm (9.2 in)	
Overall height	240 mm (9.4 in)	255.5 mm (10.1 in)
Dry weight	3.46 kg (7.6 lbs)	3.53 kg (7.8 lbs)
Operating weight	4.01kg (8.8 lbs)	4.08 kg (9.0 lbs)

• **ENGINE**

Model	GX35
Description code	GCACM
Type	4-stroke, overhead cam, single cylinder
Displacement	35.8 cm <sup>3</sup> (2.2 cu-in)
Bore x stroke	39.0 x 30.0 mm (1.5 x 1.2 in)
Net power*	1.0 kW (1.3 hp) at 7,000 rpm
Max net torque*	1.6 N•m (1.2 lbf•ft) at 5,500 rpm
Compression ratio	8.0:1
Fuel consumption	0.71 ℓ/hr at 7,000 rpm
Cooling system	Forced air
Ignition system	Transistorized magneto ignition
Ignition timing	27° B.T.D.C. (Fixed)
Spark plug	CMR5H (NGK)
Carburetor	Diaphragm type
Air cleaner	Semi-dry type
Lubrication system	Oil mist
Oil capacity	100 cc (3.4 US oz, 3.5 Imp oz)
Recommended operating ambient temperature	-5°C ~ 40°C (23°F ~ 104°F)
Starting system	Recoil starter
Stopping system	Ignition primary circuit ground
Fuel used	Unleaded gasoline with a pump octane rating of 86 or higher
Fuel capacity	0.63 ℓ (0.17 US gal, 0.14 Imp gal) (pre-2010 year)
	0.63 ℓ (0.17 US gal, 0.14 Imp gal) (low-perm, horizontal type) (Serial # GSAST-1110538 ~ 1110651, 1114891 and later)
	0.64 ℓ (0.17 US gal, 0.14 Imp gal) (low perm, vertical type) (Serial # GSAST-1116491 and later)
PTO shaft rotation	Counterclockwise (from the PTO shaft side)

\* The power rating of the engine indicated in this document is the net power output tested on a production engine for the engine model and measured in accordance with SAE J1349 at 7,000 rpm (Net power) and at 5,500 rpm (Max net torque). Mass production engines may vary from this value. Actual power output for the engine installed in the final machine will vary depending on numerous factors, including the operating speed of the engine in application, environmental conditions, maintenance, and other variables.

## 2. PERFORMANCE CURVES

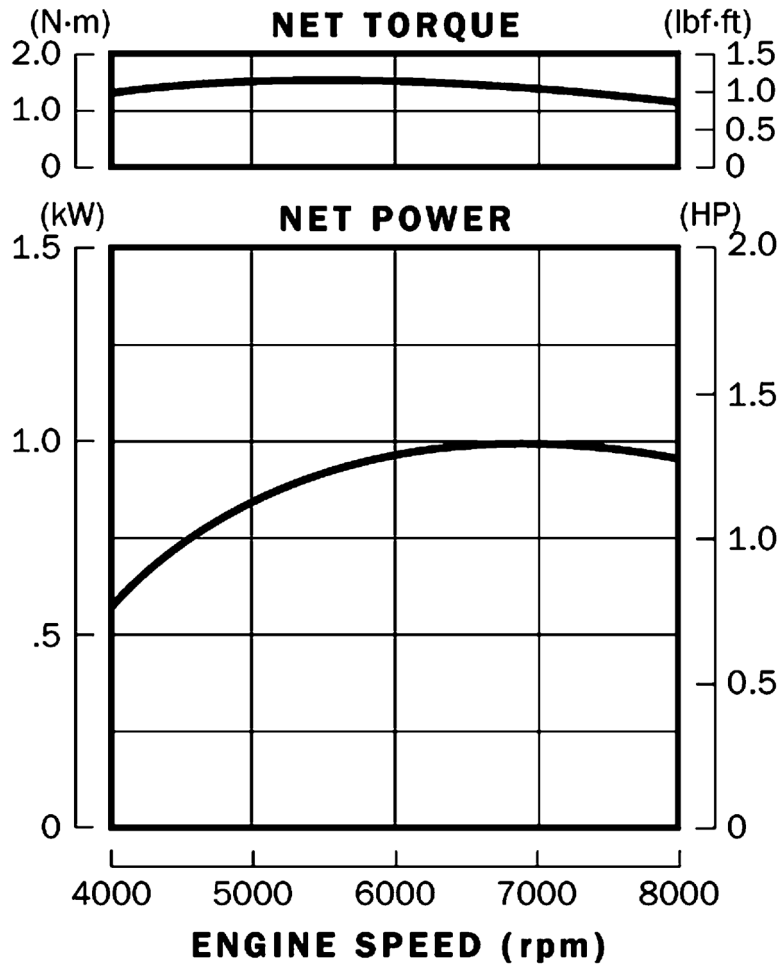

## 3. DIMENSIONAL DRAWINGS

Unit: mm (in)

[ ]: SAT, SCT type

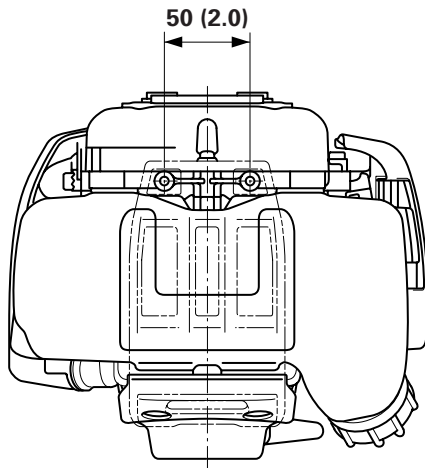
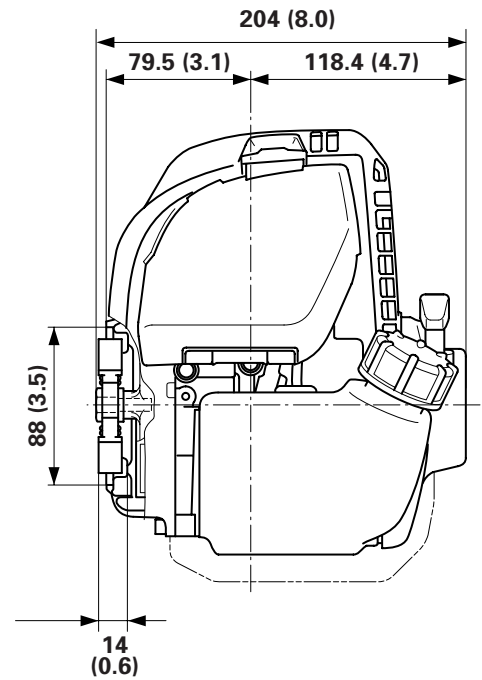
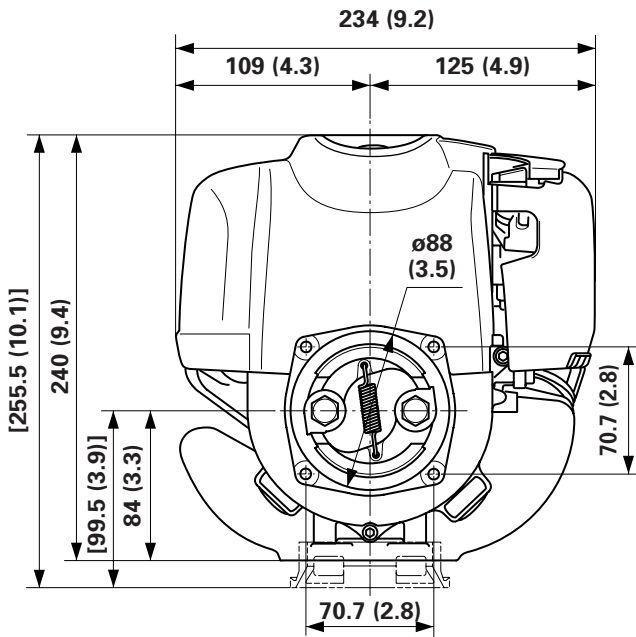

## 4. WIRING DIAGRAM

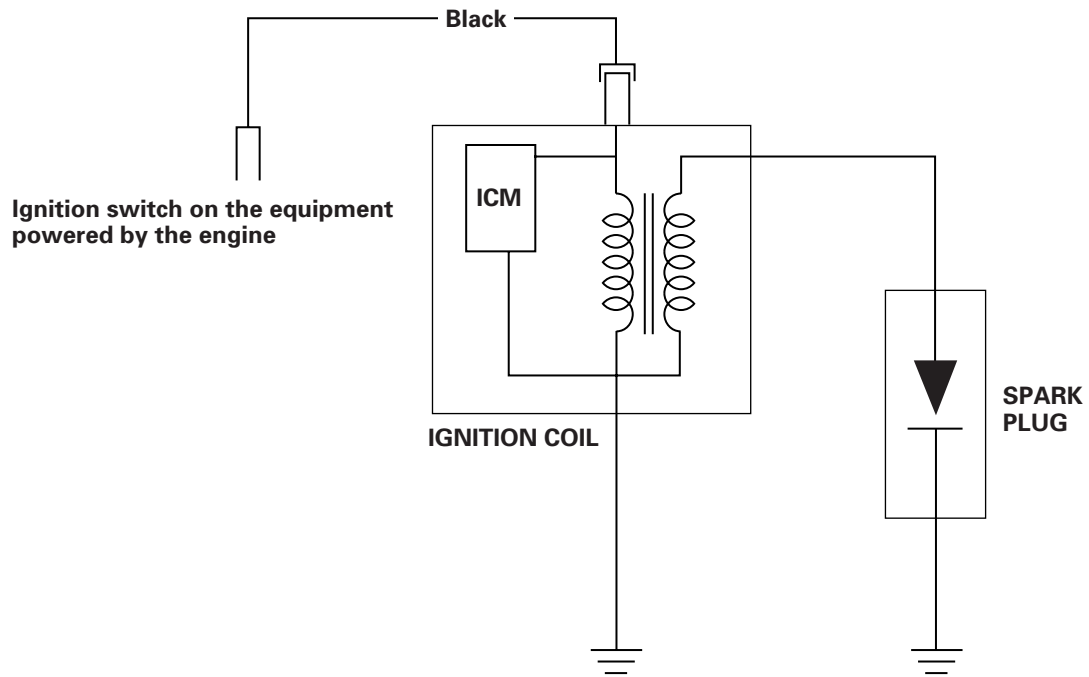

1. SYMBOLS USED IN THIS MANUAL
2. SERIAL NUMBER LOCATION
3. MAINTENANCE STANDARDS

4. TORQUE VALUES
5. SPECIAL TOOLS
6. TROUBLESHOOTING

## 1. SYMBOLS USED IN THIS MANUAL

As you read this manual, you may find the following symbols with the instructions.



A special tool is required to perform the procedure.



Apply grease



Apply oil

○ x ○ (○) Indicates the diameter, length, and quantity of metric flange bolts used.

P. ○ - ○ Indicates the reference page.

## 2. SERIAL NUMBER LOCATION

The engine serial number and type are located on the cylinder block near the fuel tank. Refer to the engine serial number and engine type when ordering parts and when making technical inquiries.

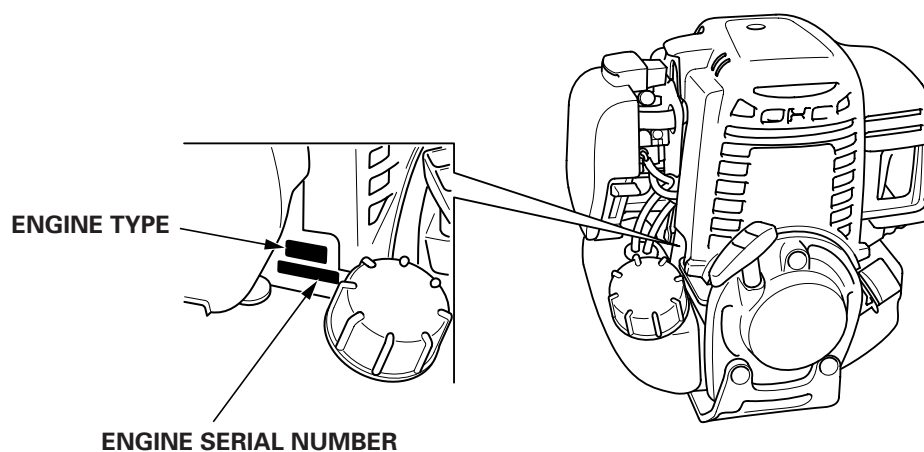

### 3. MAINTENANCE STANDARDS

Unit: mm (in)

Part	Item		Standard	Service Limit
Engine	Idle Speed		3,100 ± 200 rpm	----
	Cylinder Compression		0.95 ± 0.15 Mpa (9.7 ± 1.5 kgf/cm <sup>2</sup> , 138 ± 22 psi) at 2,000 min <sup>-1</sup> (rpm)	----
Cylinder	Sleeve I.D.		39.000 - 39.015 (1.535 - 1.536)	39.100 (1.5393)
Piston	Skirt O.D.		38.970 - 38.990 (1.534 - 1.535)	38.900 (1.5314)
	Piston-to-cylinder clearance		0.010 - 0.045 (0.0004 - 0.0018)	0.120 (0.0047)
	Piston pin bore I.D.		8.010 - 8.026 (0.3154 - 0.3160)	8.060 (0.3173)
Piston pin	Pin O.D.		7.994 - 8.000 (0.3147 - 0.3150)	7.950 (0.3130)
	Piston-pin-to-piston bore clearance		0.010 - 0.032 (0.0004 - 0.0013)	0.070 (0.0028)
Piston rings	Ring width	Top/second	0.970 - 0.990 (0.0382 - 0.0390)	0.920 (0.0362)
	Side clearance	Top/second	0.015 - 0.056 (0.0006 - 0.0022)	0.120 (0.0047)
	Ring end gap	Top/second	0.10 - 0.25 (0.004 - 0.010)	0.60 (0.024)
Connecting rod	Small end I.D.		7.978 - 7.989 (0.3141 - 0.3145)	----
Valve	Valve clearance	IN	0.08 ± 0.02	----
		EX	0.11 ± 0.02	----
	Stem O.D.	IN	3.470 - 3.485 (0.1366 - 0.1372)	3.400 (0.1339)
		EX	3.435 - 3.450 (0.1352 - 0.1358)	3.380 (0.1331)
	Guide I.D.		3.500 - 3.518 (0.1378 - 0.1385)	3.560 (0.1402)
	Stem-to-guide clearance	IN	0.015 - 0.048 (0.0006 - 0.0019)	0.098 (0.0039)
		EX	0.050 - 0.083 (0.0020 - 0.0033)	0.120 (0.0047)
Valve spring free length		21.77 (0.8570)	21.00 (0.8268)	
Cam pulley	Cam height		22.46 (0.884)	22.16 (0.8724)
	Cam pulley I.D.		4.020 - 4.070 (0.1583 - 0.1602)	4.100 (0.1614)
	Cam pulley shaft O.D.		3.990 - 4.000 (0.1571 - 0.1575)	3.950 (0.1555)
Cylinder barrel	Barrel I.D. (Cam pulley bearing)		4.000 - 4.018 (0.1575 - 0.1582)	4.050 (0.1594)
Carburetor	Main jet		# 37	----
Spark plug	Gap		0.6 - 0.7 (0.024 - 0.028)	----
Ignition coil	Resistance	Primary coil	0.75 - 0.92 Ω	----
		Secondary coil	6.1 - 9.3 kΩ	----
	Air gap (at flywheel)		0.2 - 0.4 (0.008 - 0.016)	----
Clutch	Lining thickness		2.0 (0.08)	1.0 (0.04)



**4. TORQUE VALUES**

Item	Thread dia. (mm)	Torque values		
		N·m	kgf·m	lbf·ft
Lower crankcase	M5 (CT)	6.4	0.65	4.7
Fan cover	M5 (CT)	6.4	0.65	4.7
Reed valve plate	M4	3.0	0.3	2.2
Ignition coil	M4	3.4	0.35	2.5
Recoil starter pulley	M6	6.4	0.65	4.7
Flywheel	M8	22.6	2.3	16.6
Valve adjusting lock nut	M5	4.9	0.5	3.6
Spark plug	M10	11.8	1.2	8.7
Top cover	M5	3.0	0.3	2.2
Clutch bolt	M8	15.2	1.55	11.2
Muffler	M5 (CT)	6.4	0.65	4.7
	M5 (STUD BOLT)	4.4	0.45	3.2

**NOTE:**

- CT (Cutting Thread) indicates a self-tapping bolt.
- Use standard torque values for fasteners that are not listed in this table.

**• STANDARD TORQUE VALUES**

Item	Thread Dia.	Torque values		
		N·m	kgf·m	lbf·ft
Screw	3 mm	1.0	0.1	0.7
	4 mm	2.1	0.2	1.4
Flange bolt and nut	4 mm	3.4	0.3	2.2
	5 mm	5.4	0.6	4.3
	6 mm	9.8	1.0	7.2
CT flange bolt	5 mm	5.9	0.6	4.3

## 5. TOOLS

ITEM	TOOL NAME	TOOL NUMBER	APPLICATION
①	Piston base	07VPF-ZM3010B	} Piston pin removal/installation
②	Push rod	07VPF-ZM3020A	
③	Guide	07VPF-ZM3030A	Piston pin installation
④	Rocker arm replacement tool	070PF-Z0HA100	Rocker arm removal/installation

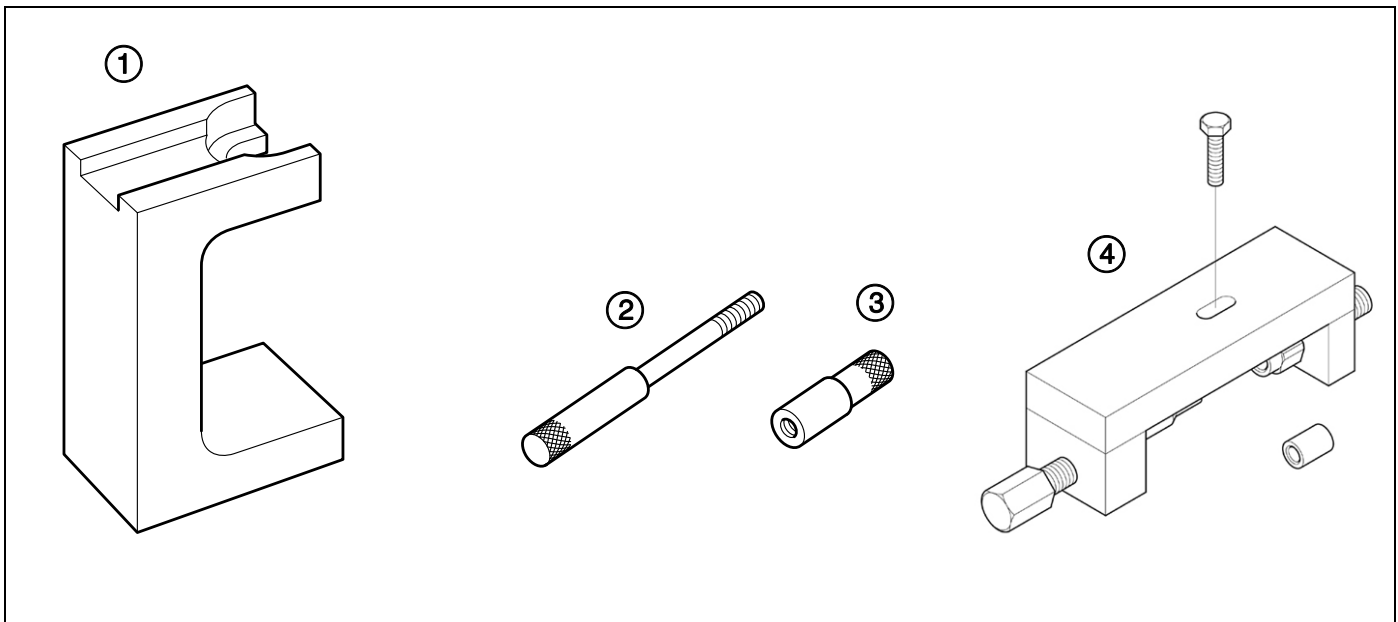

## 6. TROUBLESHOOTING

### a. GENERAL SYMPTOM AND POSSIBLE CAUSES

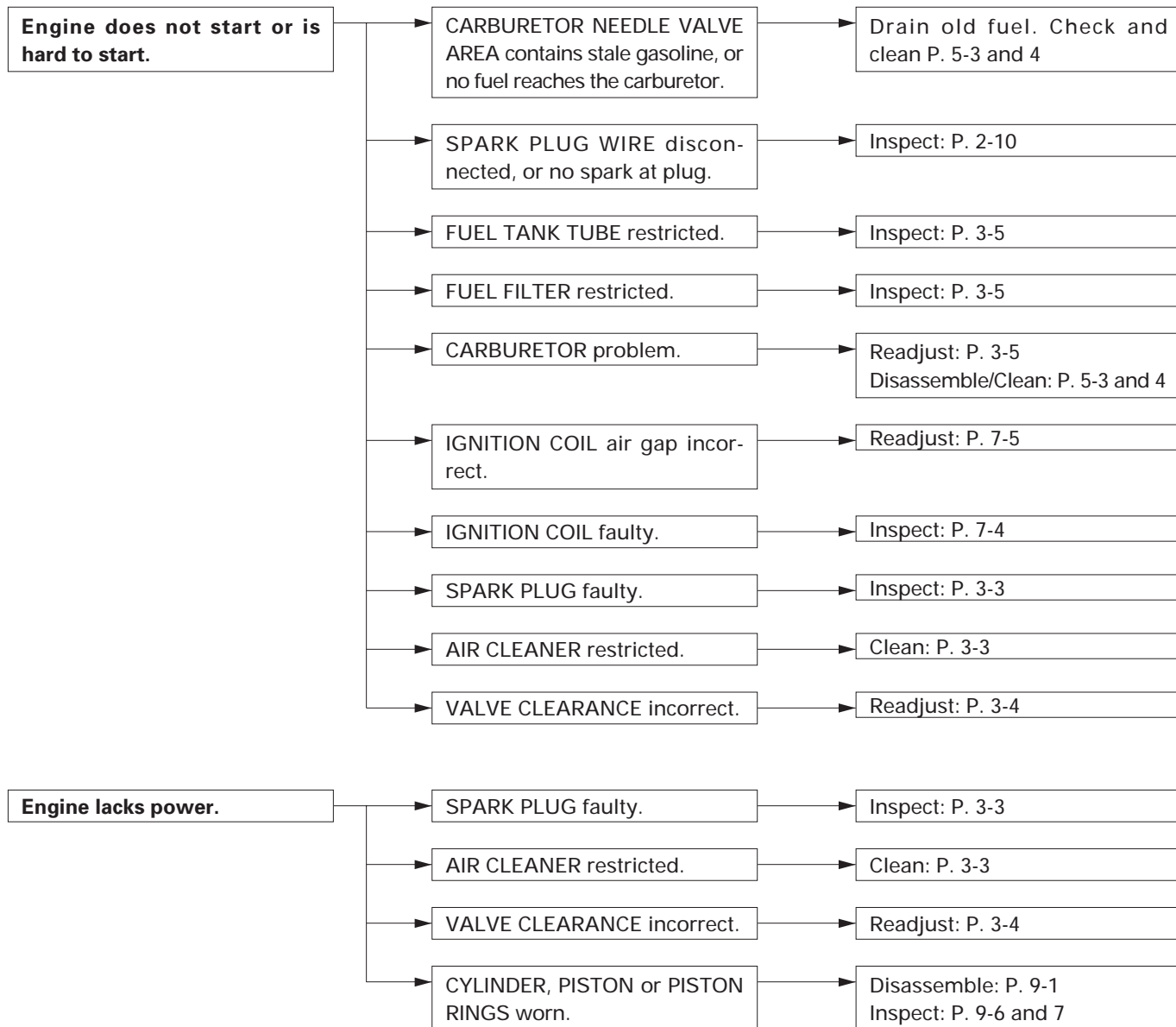

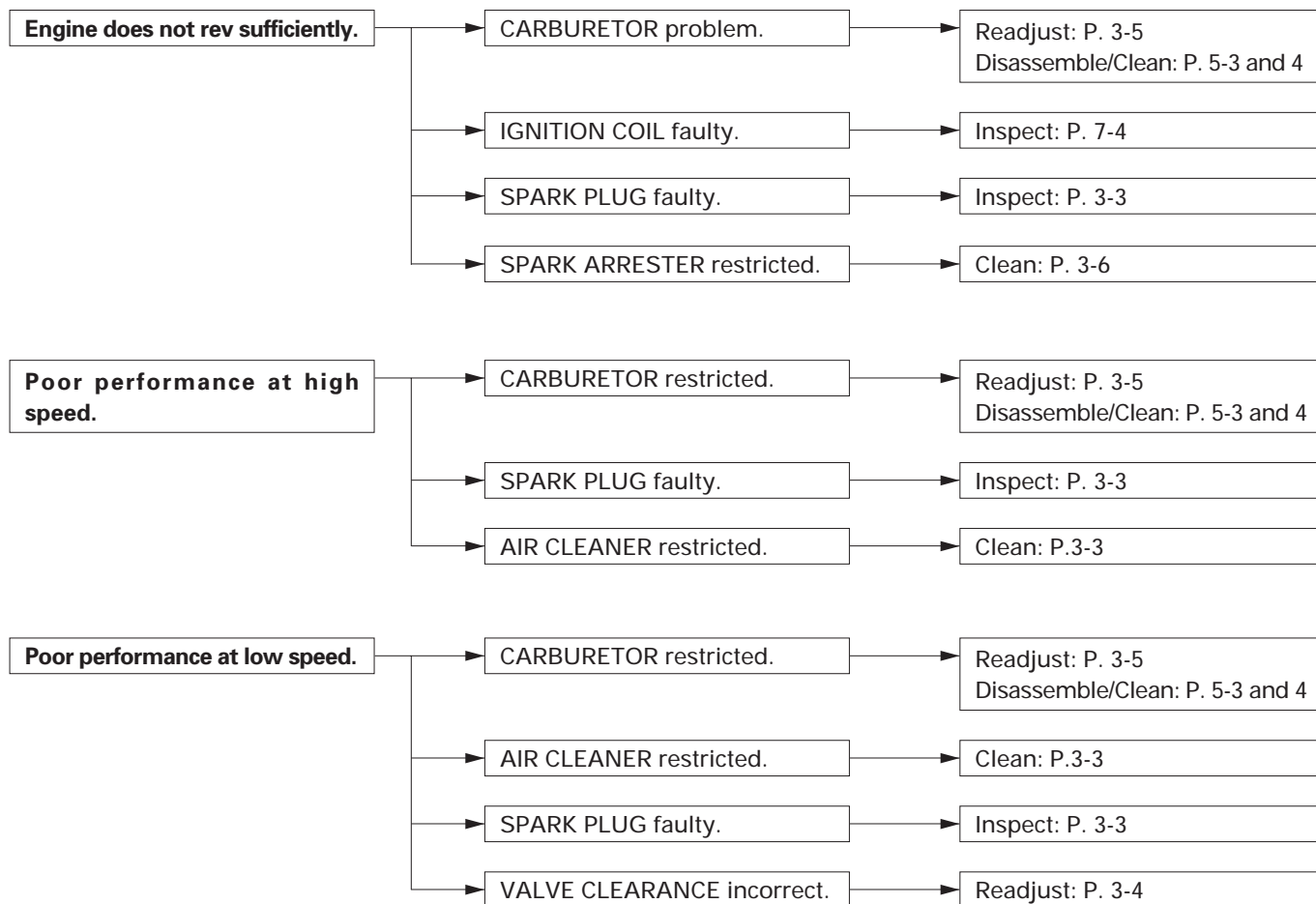

## b. ENGINE

### • Hard Starting

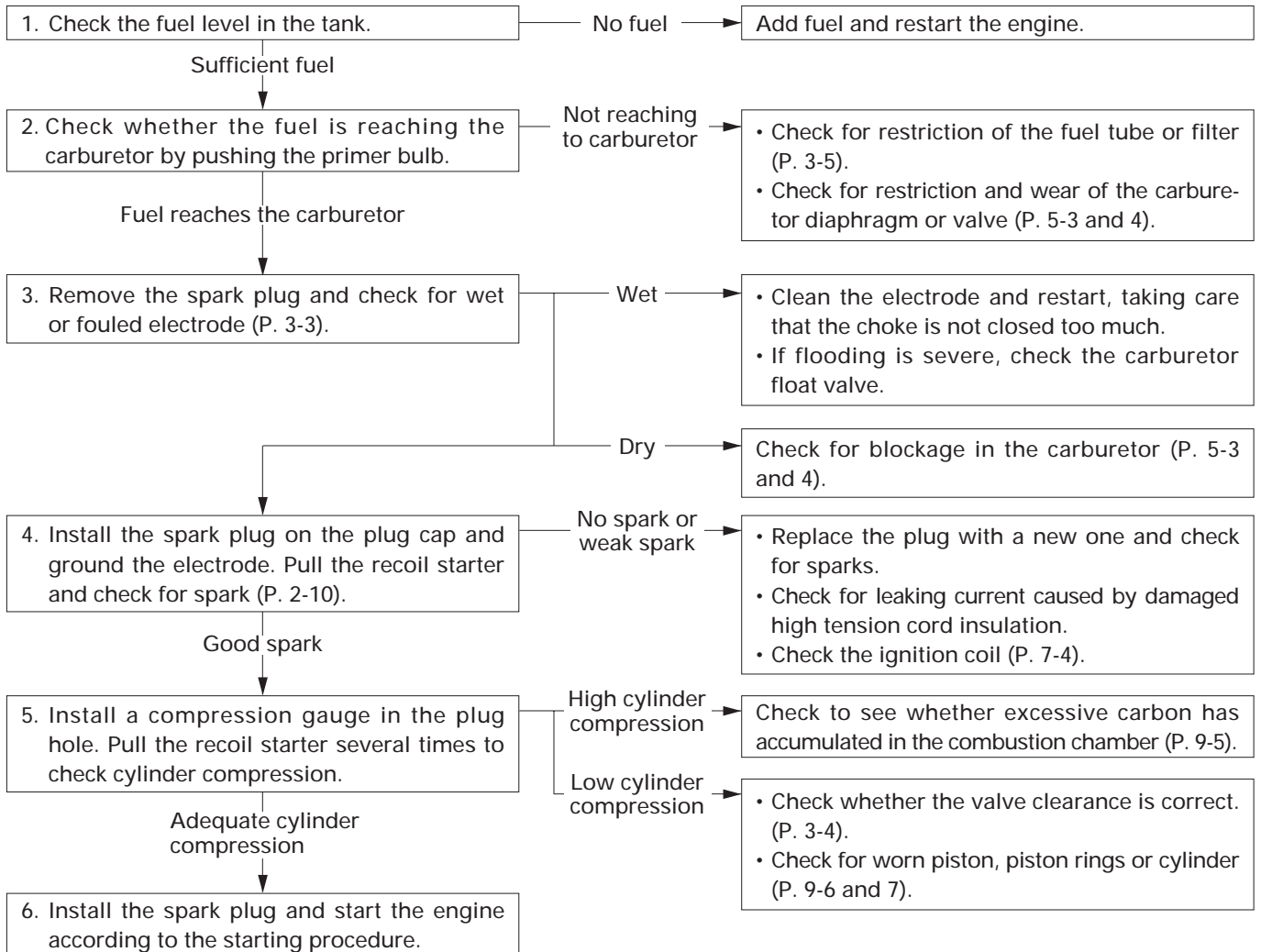

### • CYLINDER COMPRESSION CHECK

- 1) Drain the fuel tank.
- 2) Drain the gasoline by pushing the carburetor primer bulb.
- 3) Remove the spark plug cap and spark plug, and install a compression gauge in the spark plug hole.
- 4) Open the throttle wide open and make sure the choke is open.
- 5) Pull the recoil starter several times with force and measure the cylinder compression.  
Do not touch the flywheel fins when pulling the recoil starter.

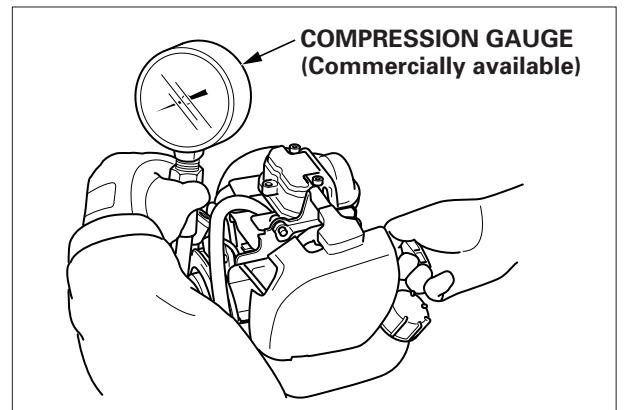

Cylinder compression	0.95 ± 0.15 MPa (9.7 ± 1.5 kgf/cm <sup>2</sup> , 138 ± 22 psi) at 2,000 min <sup>-1</sup> (rpm)
----------------------	--

**• Poor performance at low speed.**

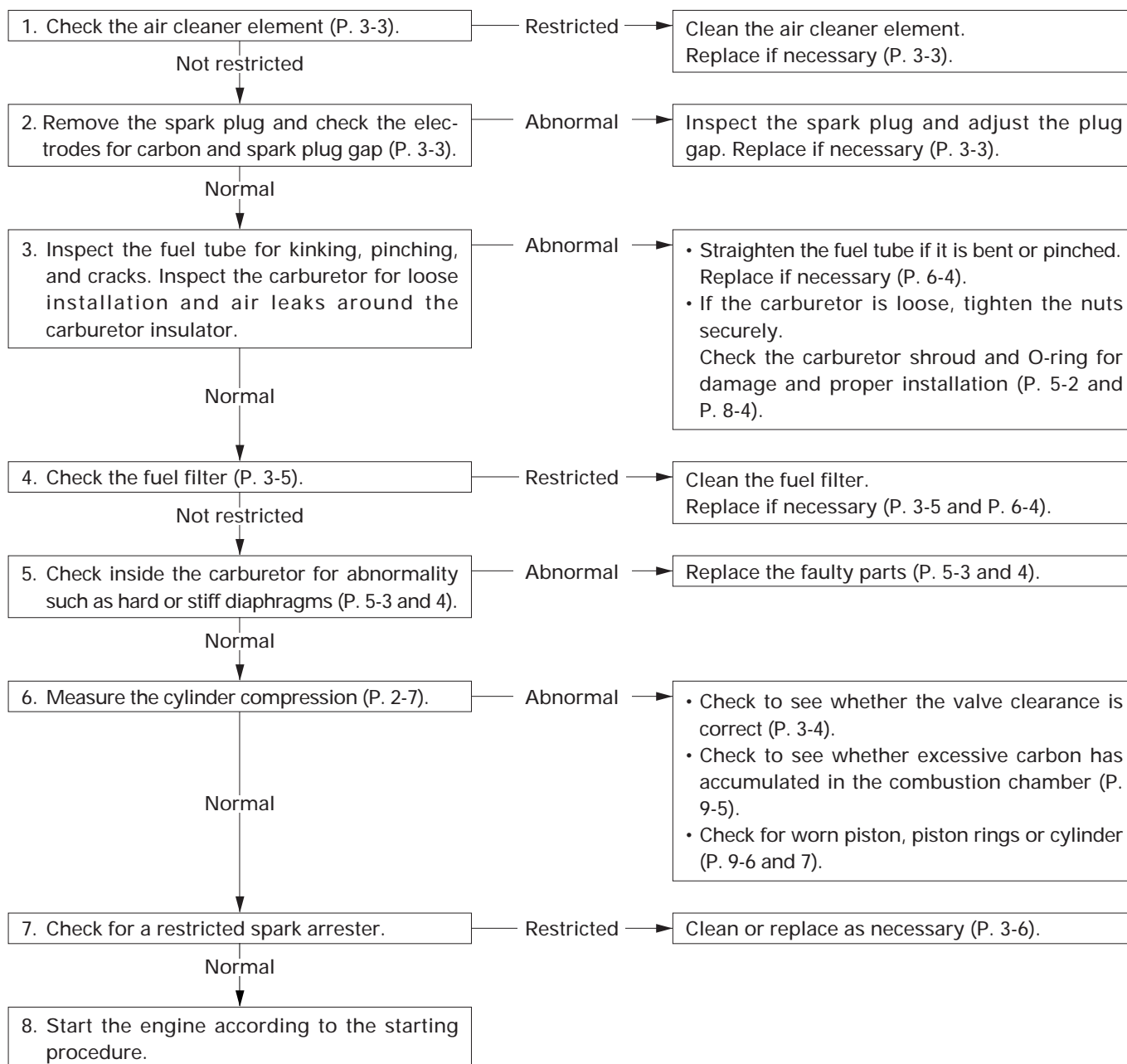

## • Poor performance at high speed.

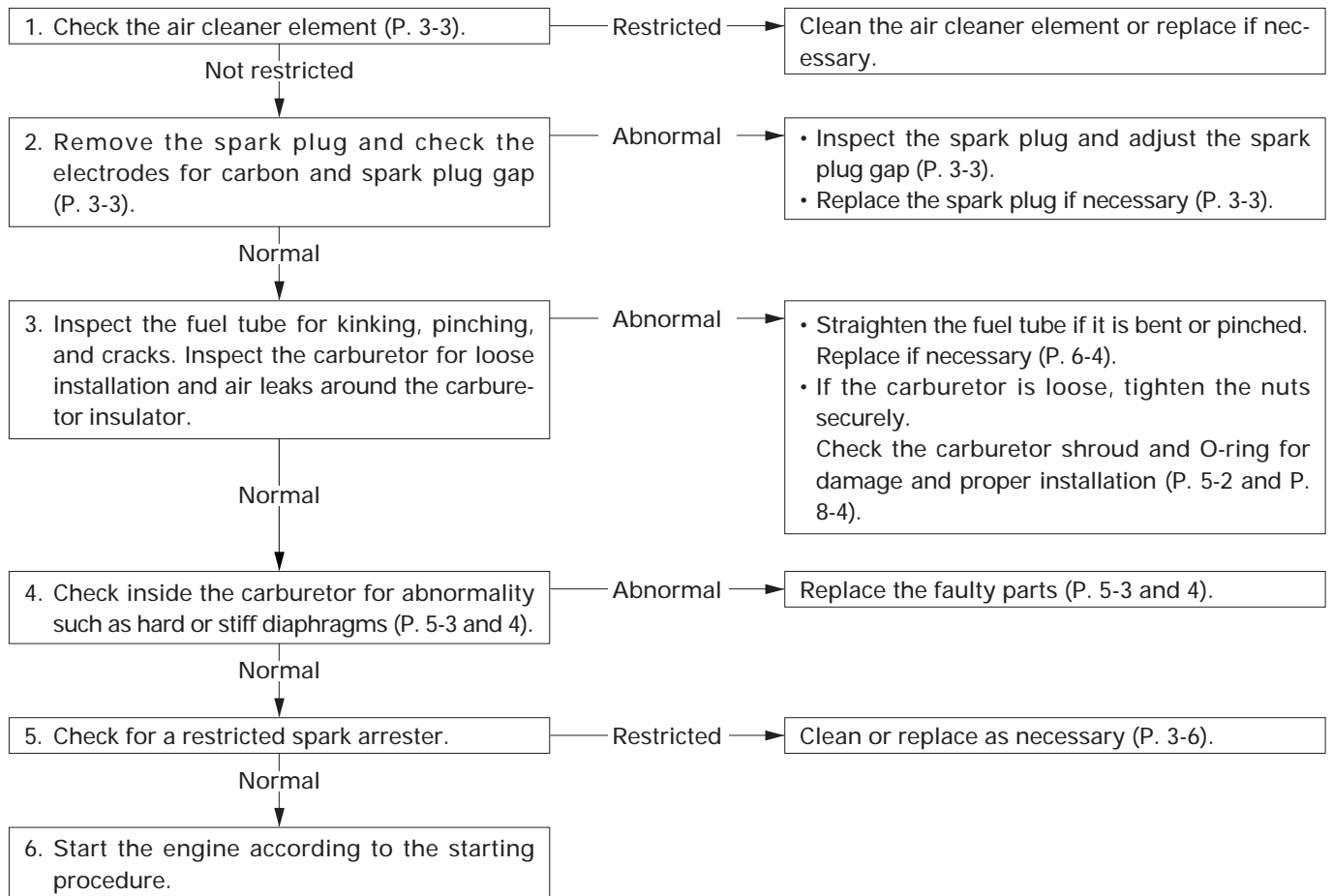

**c. IGNITION SYSTEM**

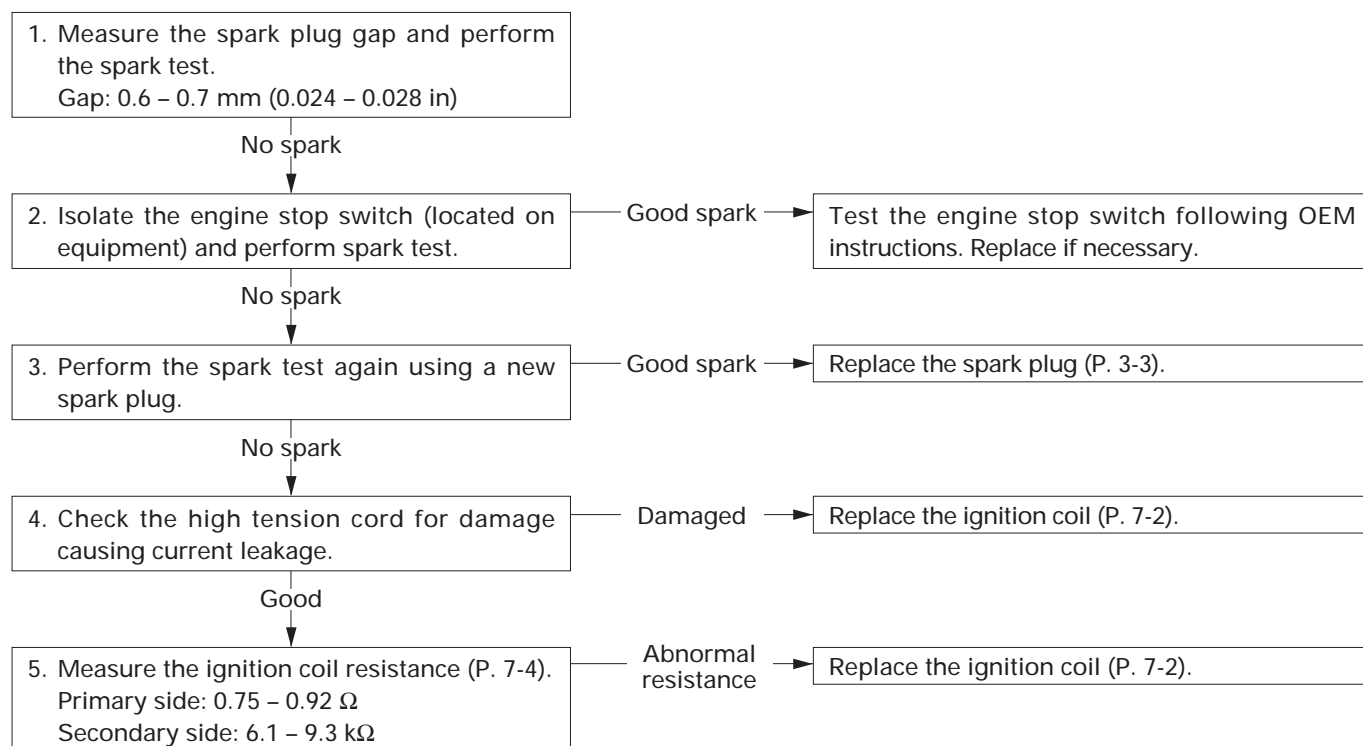

**• SPARK TEST**

**⚠ WARNING**

Gasoline is highly flammable and explosive. If ignited, gasoline can burn you severely.

- Be sure there is no spilled fuel near the engine.
- Place the spark plug away from the spark plug hole.

Drain the fuel tank and fuel line completely before testing. Unburnt gas can ignite if it is left in the cylinder.

Do not touch the flywheel fins when pulling the recoil starter.

- 1) Take out the fuel filter from the fuel tank and drain the gasoline by pushing the carburetor primer bulb.
- 2) Pull the recoil starter several times to release the unburnt gas from the cylinder before testing.
- 3) Remove the spark plug.
- 4) Install the removed spark plug on the plug cap.
- 5) Ground the negative (-) electrode of the spark plug to the engine block.  
Pull the recoil starter to check for sparks.

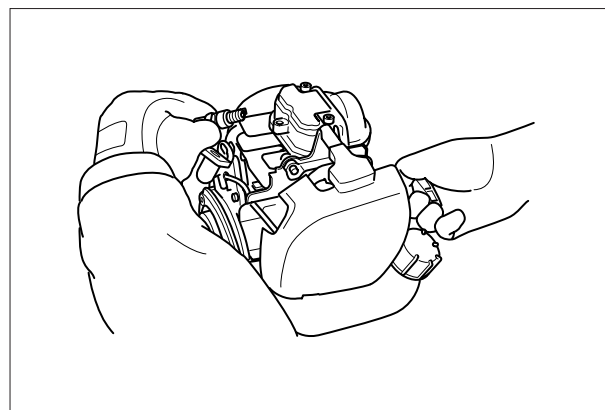



**d. PROBABLE CAUSES OF MAJOR CARBURETOR PROBLEMS**

Symptom		Start			Low speed			Acceleration/ deceleration			High speed	
		Hard starting	Overflow, fuel leaking	Hard to prime with primer bulb	Engine does not idle	Idle speed too low	Idle speed does not stabilize	Stalls when idling	Engine does not accelerate	Engine stalls at deceleration	Poor acceleration performance	Poor performance at high speed
Probable causes												
Throttle stop screw out of adjustment		<input type="checkbox"/>			<input type="checkbox"/>		<input type="checkbox"/>	<input type="checkbox"/>				
Fuel tank/tube	Fuel filter restricted	<input type="checkbox"/>		<input type="checkbox"/>	<input type="checkbox"/>		<input type="checkbox"/>	<input type="checkbox"/>	<input type="checkbox"/>			<input type="checkbox"/>
	Fuel tube restricted	<input type="checkbox"/>		<input type="checkbox"/>	<input type="checkbox"/>		<input type="checkbox"/>	<input type="checkbox"/>	<input type="checkbox"/>			<input type="checkbox"/>
	Air in fuel passage	<input type="checkbox"/>		<input type="checkbox"/>	<input type="checkbox"/>		<input type="checkbox"/>	<input type="checkbox"/>	<input type="checkbox"/>			<input type="checkbox"/>
	Incorrect/deteriorated fuel	<input type="checkbox"/>					<input type="checkbox"/>					<input type="checkbox"/>
Pump diaphragm	Vacuum pulse leaking							<input type="checkbox"/>				<input type="checkbox"/>
	Vacuum pulse passage restricted							<input type="checkbox"/>				<input type="checkbox"/>
	Loose pump cover screw		<input type="checkbox"/>					<input type="checkbox"/>				<input type="checkbox"/>
	Pump diaphragm faulty							<input type="checkbox"/>	<input type="checkbox"/>			<input type="checkbox"/>
Primer bulb	Primer bulb damaged			<input type="checkbox"/>								
	Check valve faulty	<input type="checkbox"/>		<input type="checkbox"/>			<input type="checkbox"/>	<input type="checkbox"/>	<input type="checkbox"/>			<input type="checkbox"/>
Carburetor not installed securely					<input type="checkbox"/>		<input type="checkbox"/>	<input type="checkbox"/>				<input type="checkbox"/>
Insulator gasket faulty					<input type="checkbox"/>		<input type="checkbox"/>	<input type="checkbox"/>				<input type="checkbox"/>
Metering lever	Lever damaged	<input type="checkbox"/>	<input type="checkbox"/>			<input type="checkbox"/>		<input type="checkbox"/>				<input type="checkbox"/>
	Lever too high		<input type="checkbox"/>			<input type="checkbox"/>		<input type="checkbox"/>	<input type="checkbox"/>			
	Lever too low							<input type="checkbox"/>				
	Lever not operating properly	<input type="checkbox"/>	<input type="checkbox"/>	<input type="checkbox"/>	<input type="checkbox"/>	<input type="checkbox"/>	<input type="checkbox"/>	<input type="checkbox"/>	<input type="checkbox"/>	<input type="checkbox"/>		<input type="checkbox"/>
Metering lever spring	Spring deformed		<input type="checkbox"/>					<input type="checkbox"/>				<input type="checkbox"/>
	Spring not installed properly						<input type="checkbox"/>	<input type="checkbox"/>	<input type="checkbox"/>			<input type="checkbox"/>
Metering diaphragm	Diaphragm damaged	<input type="checkbox"/>	<input type="checkbox"/>	<input type="checkbox"/>			<input type="checkbox"/>	<input type="checkbox"/>				<input type="checkbox"/>
	Gasket faulty	<input type="checkbox"/>	<input type="checkbox"/>	<input type="checkbox"/>								<input type="checkbox"/>
Inlet needle valve	Stuck valve	<input type="checkbox"/>		<input type="checkbox"/>				<input type="checkbox"/>				
	Worn valve	<input type="checkbox"/>	<input type="checkbox"/>			<input type="checkbox"/>	<input type="checkbox"/>	<input type="checkbox"/>		<input type="checkbox"/>		<input type="checkbox"/>
	Foreign matter stuck in valve	<input type="checkbox"/>	<input type="checkbox"/>			<input type="checkbox"/>	<input type="checkbox"/>	<input type="checkbox"/>		<input type="checkbox"/>		<input type="checkbox"/>

<b>1. MAINTENANCE SCHEDULE</b>	<b>5. VALVE CLEARANCE</b>
<b>2. ENGINE OIL</b>	<b>6. CARBURETOR</b>
<b>3. AIR CLEANER</b>	<b>7. FUEL TANK/FUEL FILTER</b>
<b>4. SPARK PLUG</b>	<b>8. SPARK ARRESTER</b>

## 1. MAINTENANCE SCHEDULE

REGULAR SERVICE PERIOD (2)		Each use	First month or 10 Hrs.	Every 3 months or 25 Hrs.	Every 6 months or 50 Hrs.	Every year or 100 Hrs.	Every 2 years or 300 Hrs.	Refer to page
ITEM	Perform at every indicated month or operating hour interval, whichever comes first.							
Engine oil	Check level	○						P. 3-2
	Change		○		○			
Air filter	Check	○						P. 3-3
	Clean			○ (1)				
Spark plug	Check-adjust					○		P. 3-3
	Replace						○	
Spark arrester	Clean					○		P. 3-6
Engine cooling fins	Check				○			----
Nuts, bolts, fasteners	Check (Retighten if necessary)	○						----
Clutch shoes	Check				○			P. 7-4
Idle speed	Check-adjust					○		P. 3-5
Valve clearance	Check-adjust					○		P. 3-4
Combustion chamber	Clean	After every 300 hrs						----
Fuel filter	Check					○		P. 3-6
Fuel tank	Clean					○		P. 3-5
Fuel tubes	Check	Every 2 years (Replace if necessary)						P. 6-4
Oil tube	Check	Every 2 years (Replace if necessary)						----

(1) Service more frequently when used in dusty areas.

(2) For commercial use, log hours of operation to determine proper maintenance intervals.

## 2. ENGINE OIL

### Inspection:

Check the engine oil level with the engine stopped and the engine on a level surface.

- 1) Remove the oil filler cap, and wipe the dipstick clean.
- 2) Insert the dipstick in the oil filler neck, but do not screw it in. Remove the dipstick and check the oil level.
- 3) If the oil level is low, fill to the bottom of the oil filler neck with the recommended oil. Do not overfill.
- 4) Tighten the oil filler cap securely.

### Oil Change:

- 1) Check that the fuel tank cap is tightened securely.
- 2) Remove the oil filler cap. Tilt the engine toward the oil filler cap side and drain the used oil into a suitable container.

Please dispose of used motor oil in a manner that is compatible with the environment. We suggest you take used oil in a sealed container to your local recycling center or service station for reclamation. Do not throw it in the trash, pour it on the ground, or down a drain.

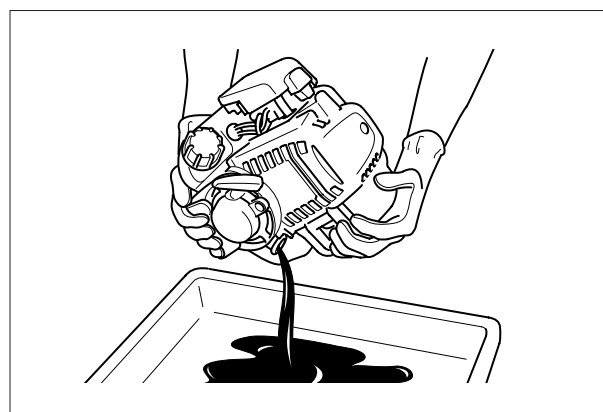
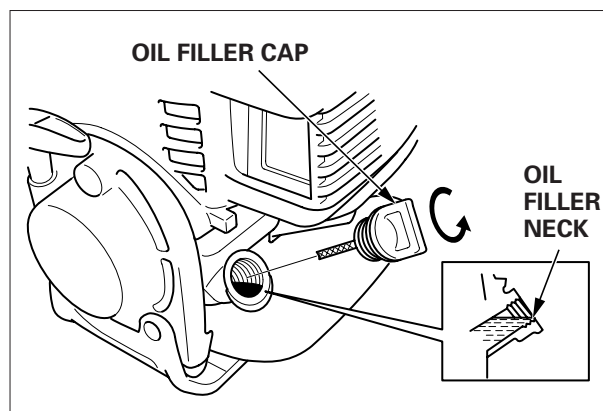

### CAUTION

Used engine oil contains substances that have been identified as carcinogenic.

If repeatedly left in contact with the skin for prolonged periods, it may cause skin cancer.

Wash your hands thoroughly with soap and water as soon as possible after contact with used engine oil.

- 3) With the engine on a level surface, refill with the recommended oil to the bottom of the oil filler neck.

Engine oil capacity	100 cc (3.4 US oz, 3.5 Imp oz)
---------------------	--------------------------------

Recommended operating ambient temperature	- 5 °C ~ 40 °C (23 °F ~ 104 °F)
---	------------------------------------

The SAE oil viscosity and service classification are in the API label on the oil container. Honda recommends that you use API SERVICE category SJ oil.

- 4) Tighten the oil filler cap securely.

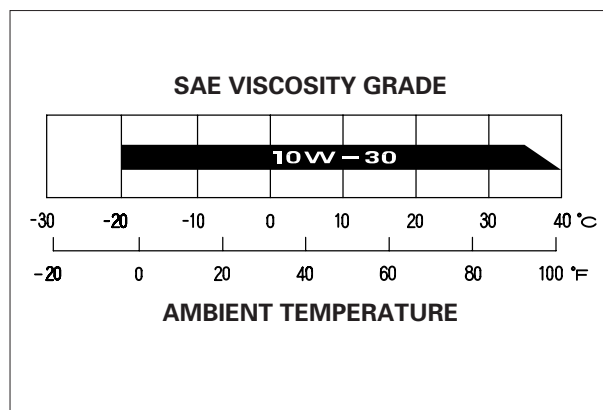

### 3. AIR CLEANER

**Cleaning:**

A dirty air filter will restrict air flow to the carburetor, reducing engine performance. If the filter is operated in dusty areas, clean the air filter more often than specified in the MAINTENANCE SCHEDULE.

**NOTICE**

*Operating the engine without an air filter or with a damaged air filter, will allow dirt to enter the engine, causing rapid engine wear. This type of damage is not covered by the Distributor's Limited Warranty.*

- 1) Remove the air cleaner cover and remove the air filter.
- 2) Carefully check the air filter for holes or tears, and replace if damaged.
- 3) Clean in warm, soapy water, rinse, and allow to dry. Or clean in nonflammable solvent and allow to dry. Dip the air filter in clean engine oil, then squeeze out all excess oil. The engine will smoke if too much oil is left in the foam.  
Wipe dirt from the inside of the air cleaner cover and air cleaner case, using a moist rag.
- 4) Install the air cleaner cover.

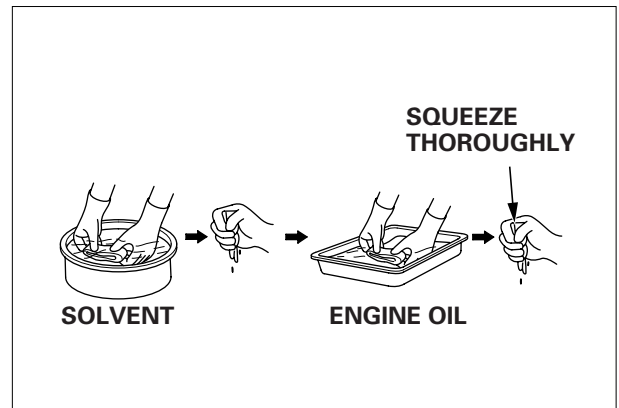
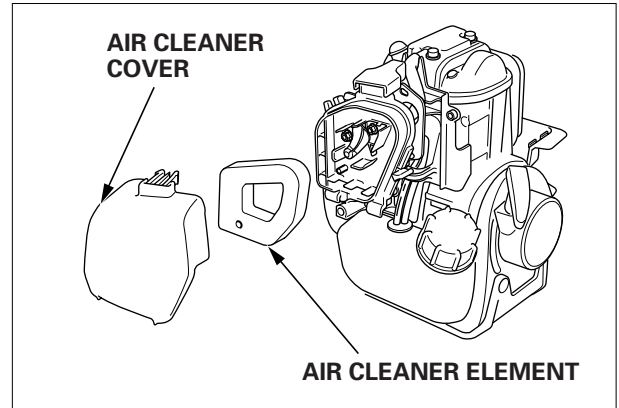

### 4. SPARK PLUG

**Inspection/Adjustment:**

If the engine has been running, the engine will be very hot. Allow it to cool before proceeding.

- 1) Remove the 5 x 14 mm top cover bolt and top cover.
- 2) Clean any dirt from around the spark plug.
- 3) Remove the plug cap, and use a spark plug wrench to remove the plug.

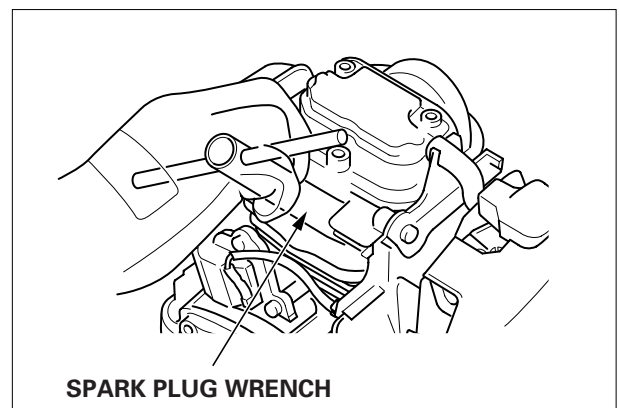
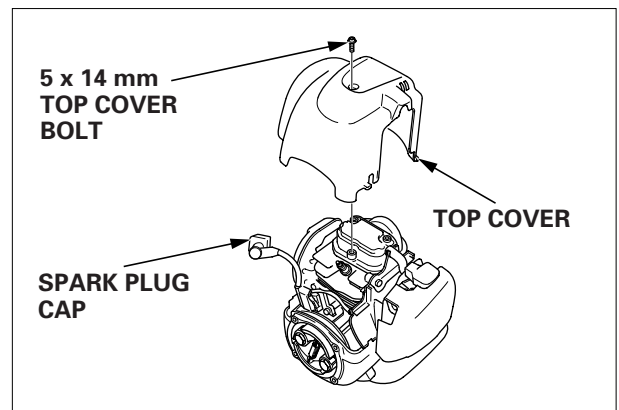

- 4) Visually inspect the spark plug. Discard the plug if the insulator is cracked or chipped.
- 5) Measure the plug gap with a wire-type feeler gauge.

Standard spark plug	CMR5H (NGK)
---------------------	-------------

If necessary, adjust the gap by bending the side electrode.

- 6) Make sure the sealing washer is in good condition; replace the plug if necessary.
- 7) Install the plug fingertight to seat the washer, then tighten with a plug wrench (an additional 1/2 turn if a new plug) to compress the sealing washer. If you are reusing a plug, tighten 1/8-1/4 turn after the plug seats.

Spark plug gap	0.6 - 0.7 mm (0.024 - 0.028 in)
----------------	---------------------------------

**NOTICE**

*A loose spark plug can become very hot and can damage the engine. Overtightening the spark plug can damage the threads in the engine.*

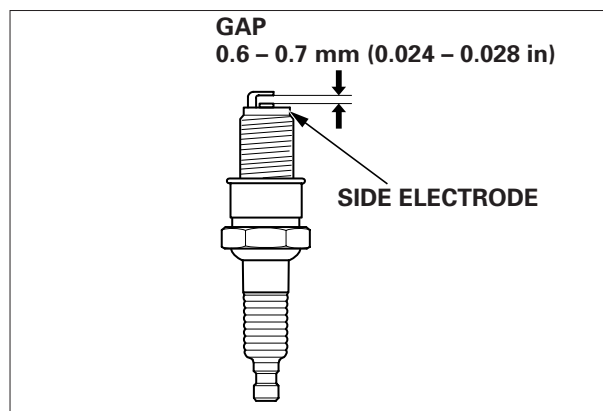

## 5. VALVE CLEARANCE

**Inspection/Adjustment:**

Valve clearance inspection and adjustment must be performed with the engine cold.

- 1) Remove the 5 x 14 mm top cover bolt and remove the top cover.
- 2) Remove the two 5 x 12 mm hex bolt from the head cover.

- Engine oil can leak out when removing the head cover. Catch the leaking oil with a suitable material and wipe up the area immediately.

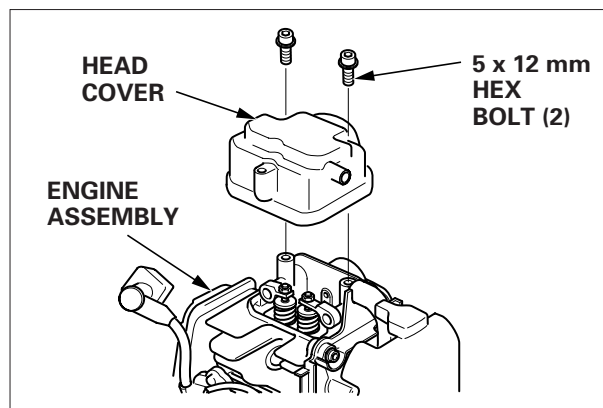
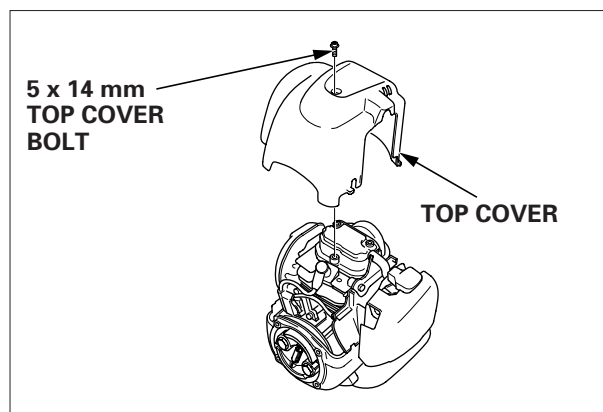

- 3) Set the piston at top dead center of the compression stroke. Align the "△" mark on the cam pulley with the cylinder head center.
- 4) Insert a feeler gauge between the rocker arm and valve to measure the valve clearance.

Standard valve clearance	IN	0.08 ± 0.02 mm
	EX	0.11 ± 0.02 mm

- 5) If adjustment is necessary proceed as follows:
  - a. Loosen the adjusting screw lock nut and adjust the valve clearance by turning the adjusting screw right or left.
  - b. Holding the adjusting screw with the tappet adjusting wrench, tighten the lock nut to the specification.

**TORQUE: 4.9 N·m (0.5 kgf·m, 3.9 lbf·ft)**

- c. After tightening the lock nut recheck the valve clearance.

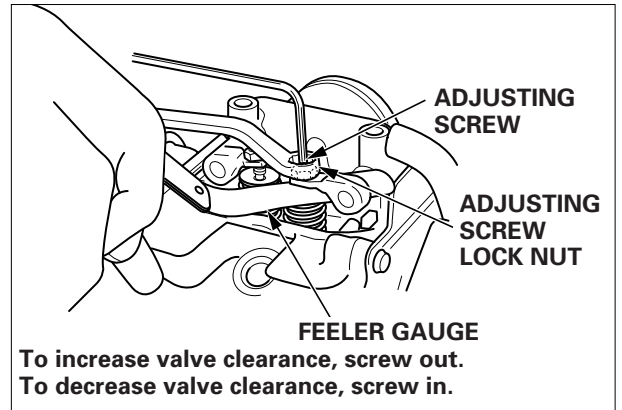
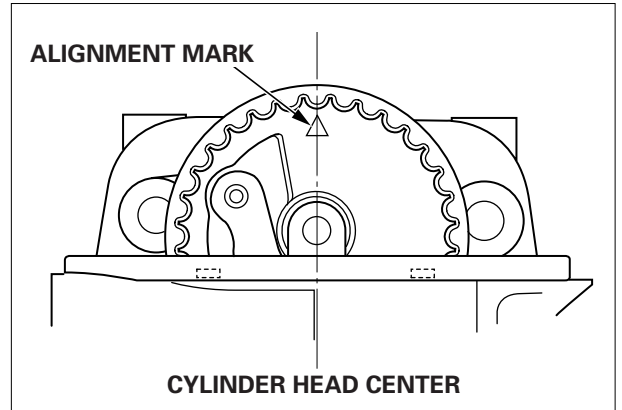

## 6. CARBURETOR

### Idle speed adjustment:

Start the engine and allow it to warm up to normal operating temperature. Then, adjust the idle speed by turning the throttle stop screw right or left.

Standard idle speed	3,100 ± 200 rpm
---------------------	-----------------

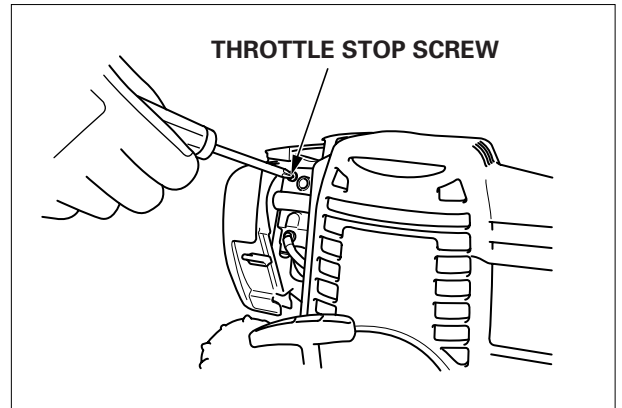

## 7. FUEL TANK/FUEL FILTER

### ⚠ WARNING

Gasoline is highly flammable and explosive.

You can be burned or seriously injured when handling fuel.

- Keep heat, sparks, and flame away.
- Handle fuel only outdoors.
- Wipe up spills immediately.

### Cleaning:

Loosen the fuel tank cap and release the pressure from the tank before operation.

- 1) Drain the fuel tank and remove the recoil starter (P. 6-1).
- 2) Remove the fuel tank.

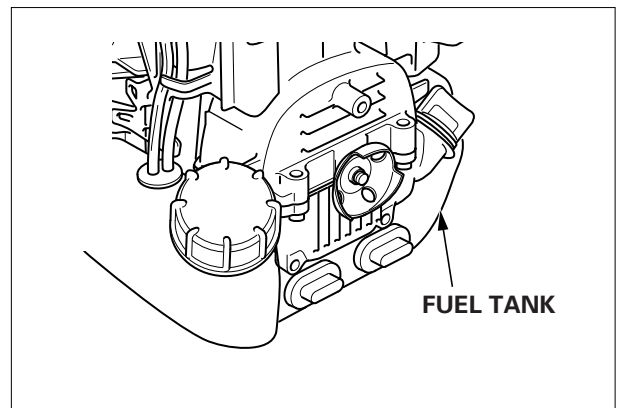

- 3) Remove the fuel filter from the fuel tube.  
Wash inside the fuel tank with nonflammable solvent to remove any foreign material and water from the tank.

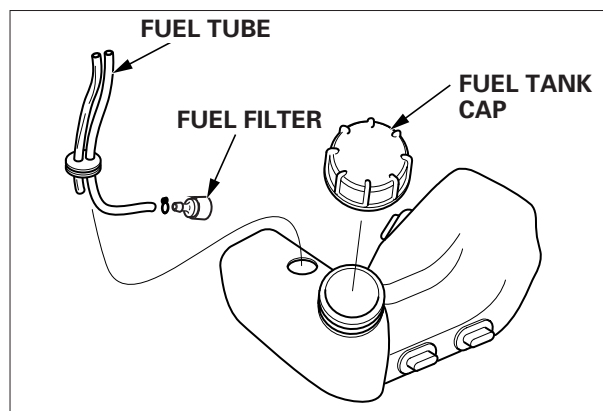

- 4) Remove the fuel filter. Clean the fuel filter with solvent and allow it to dry thoroughly.  
Replace the fuel filter if it is contaminated.
- 5) Install the fuel filter in the fuel tube.  
Install the fuel tube grommet in the fuel tank securely, then install the fuel tank and recoil starter (P. 6-1).

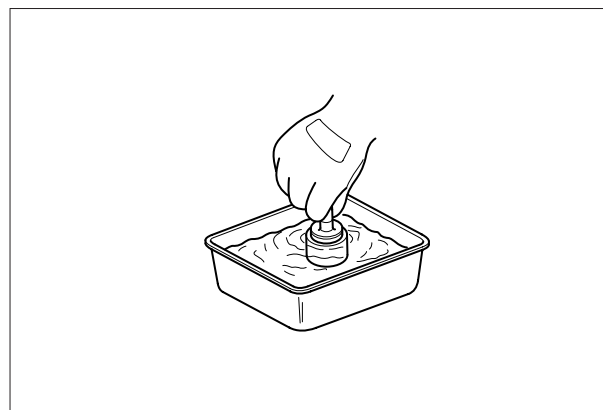

## 8. SPARK ARRESTER

### **⚠ CAUTION**

The muffler becomes very hot during operation and remains hot for a while after stopping the engine. Be careful not to touch the muffler while it is hot. Allow it to cool before proceeding.

The spark arrester must be serviced every 100 hours to maintain its efficiency.

#### **Cleaning:**

- 1) Remove the top cover (P. 4-1).
- 2) Remove the 4 x 6 mm tapping screw from the spark arrester, and remove the spark arrester from the muffler.
- 3) Check for carbon deposits around the exhaust port and spark arrester. Clean if necessary, with a wire brush.
- 4) Replace the spark arrester if there are any breaks or tears.
- 5) Install the spark arrester, muffler cover, top cover and recoil starter in the reverse order of removal.

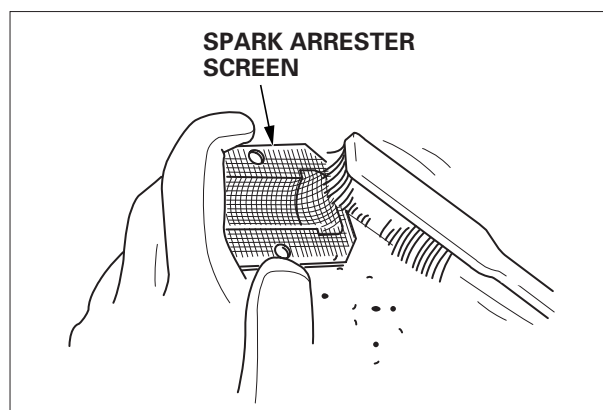
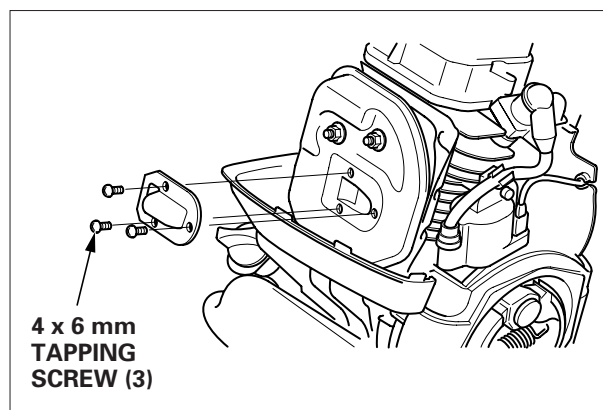

**1. TOP COVER/MUFFLER**

## 1. TOP COVER/MUFFLER

### a. REMOVAL/INSTALLATION

#### **⚠ CAUTION**

The engine and muffler become very hot during operation and they remain hot for a while after operation. Be sure that the engine is cold before muffler removal/installation.

**MUFFLER COMP.**

**REASSEMBLY:**

- Before installing, remove any carbon deposits from the muffler using a plastic hammer.
- Do not tap on the muffler seal flange to avoid damaging this part.
- If the seal flange is dented or damaged, replace the muffler.
- Check the cylinder exhaust port for damage.

**MUFFLER SEAL FLANGE**

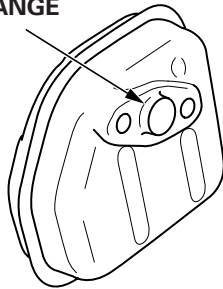

**5 x 14 mm TOP COVER BOLT**

3.0 N·m (0.3 kgf·m, 2.2 lbf·ft)

**TOP COVER Comp.**

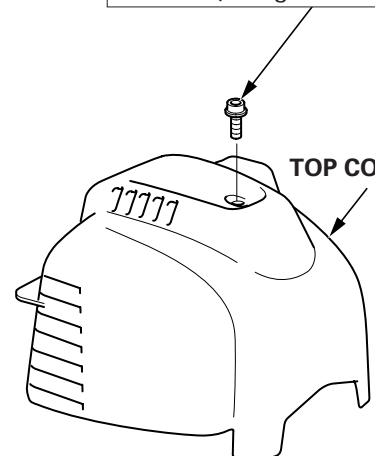

**5 mm STUD BOLT (2)**

4.4 N·m (0.45 kgf·m, 3.2 lbf·ft)

**AIR EXHAUST GUIDE**

**5 mm SELF-LOCKING NUT (2)**

6.4 N·m (0.65 kgf·m, 4.6 lbf·ft)

**4 x 6 mm TAPPING SCREW (3)**

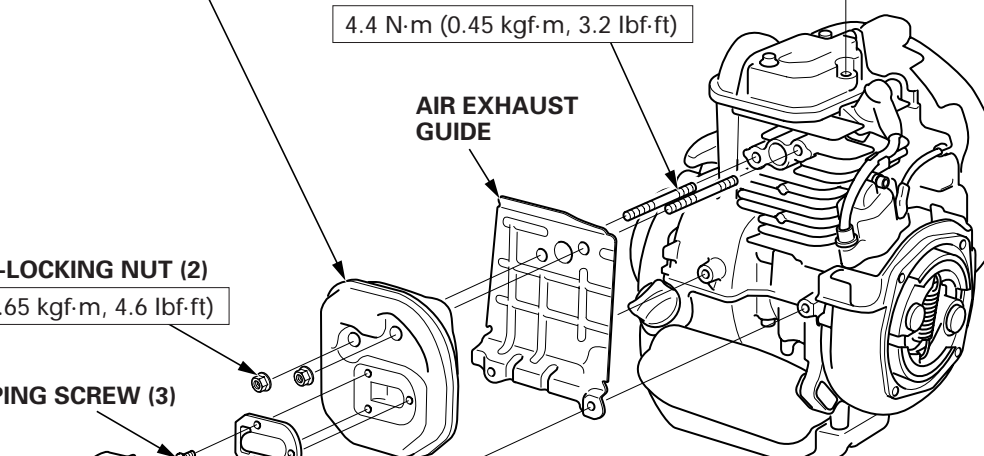

**SPARK ARRESTER**

**REASSEMBLY:**

Install after removing the carbon from the screen with a wire brush.

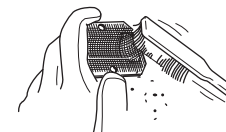

**UNDER AIR GUIDE Comp.**

**HEAD COVER COLLAR A (2)**

**5 x 16 mm HEX BOLT (2)**



**1. AIR CLEANER**

**2. CARBURETOR**

## 1. AIR CLEANER

### a. REMOVAL/INSTALLATION

**NOTICE**

*If these parts are left out, dirt will enter the intake system damaging the engine.*

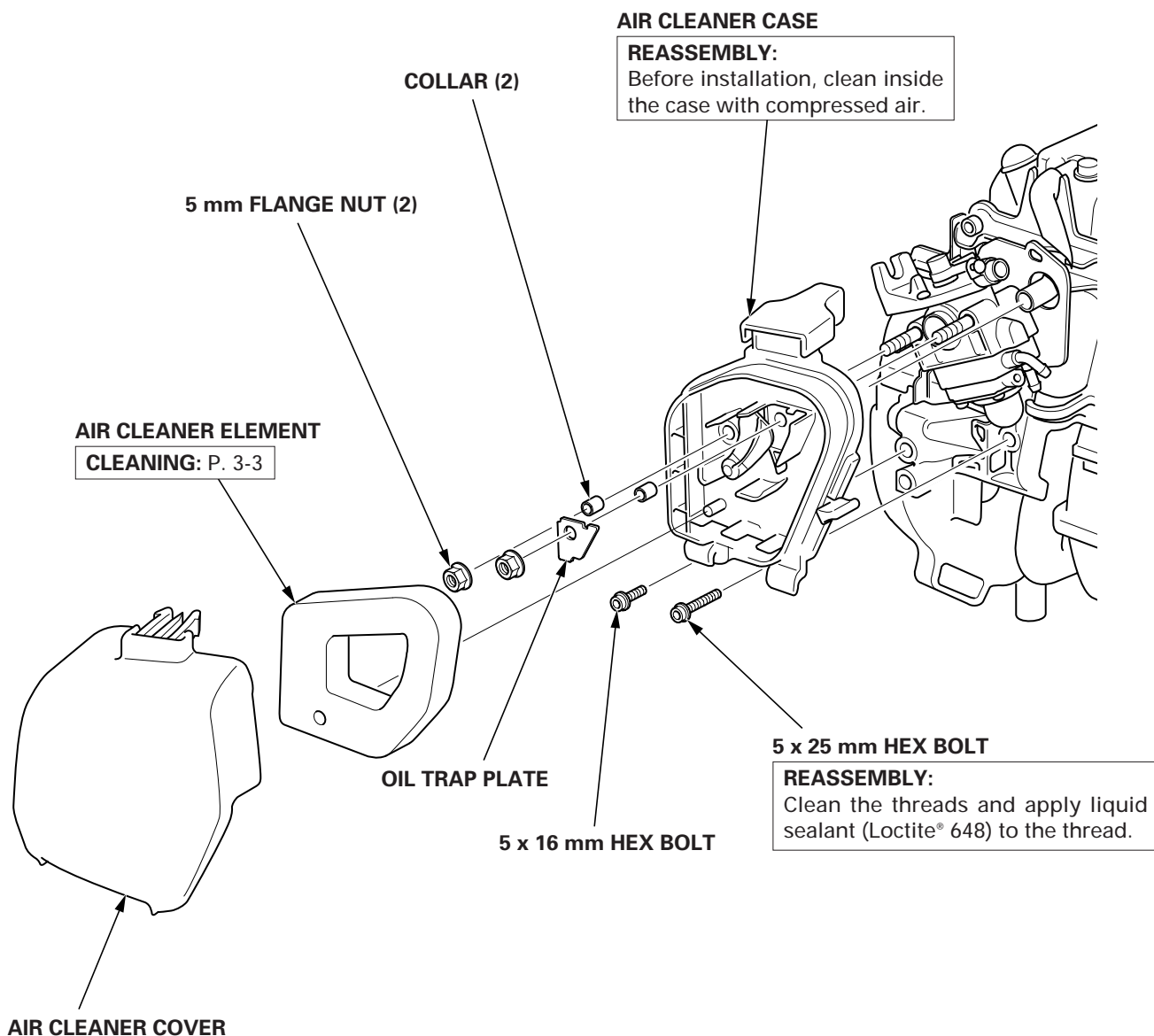

## 2. CARBURETOR

### a. REMOVAL/INSTALLATION

#### **⚠ WARNING**

Gasoline is highly flammable and explosive.

You can be burned or seriously injured when handling fuel.

- Keep heat, sparks, and flame away.
- Handle fuel only outdoors.
- Wipe up spills immediately.

#### **NOTICE**

- If these parts are left out, dirt will enter the intake system damaging the engine.
- If the carburetor is only removed, do not tip the engine toward the muffler. The 5 x 53 mm hex bolt will fall out of the shroud.

- 1) Remove the top cover (P. 4-1).
- 2) Remove the air cleaner (P. 5-1).
- 3) Drain the fuel tank, then drain the carburetor by pushing the primer bulb.

#### **BREATHER TUBE**

##### **REASSEMBLY:**

Before installing the breather line check for deterioration or damage. Replace if necessary.

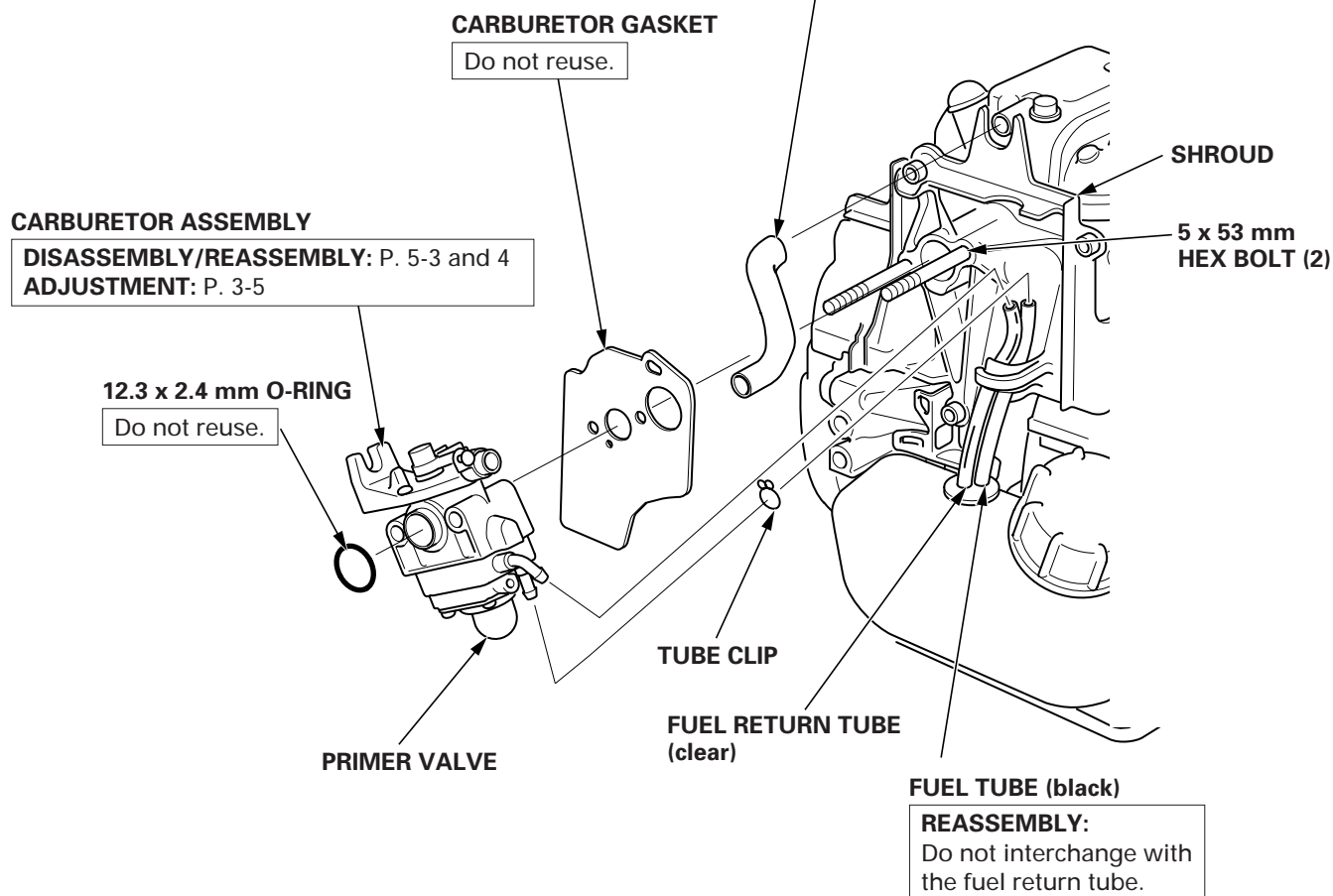
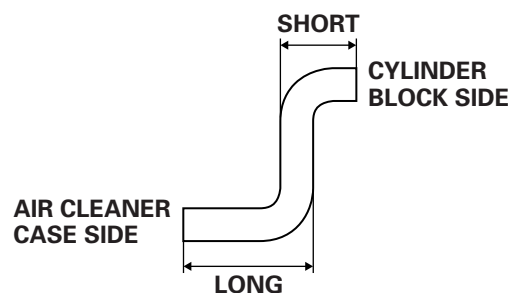

**b. DISASSEMBLY/REASSEMBLY**

**⚠ WARNING**

Gasoline is highly flammable and explosive.

You can be burned or seriously injured when handling fuel.

- Keep heat, sparks, and flame away.
- Handle fuel only outdoors.
- Wipe up spills immediately.

Clean the outside of the carburetor before disassembly.

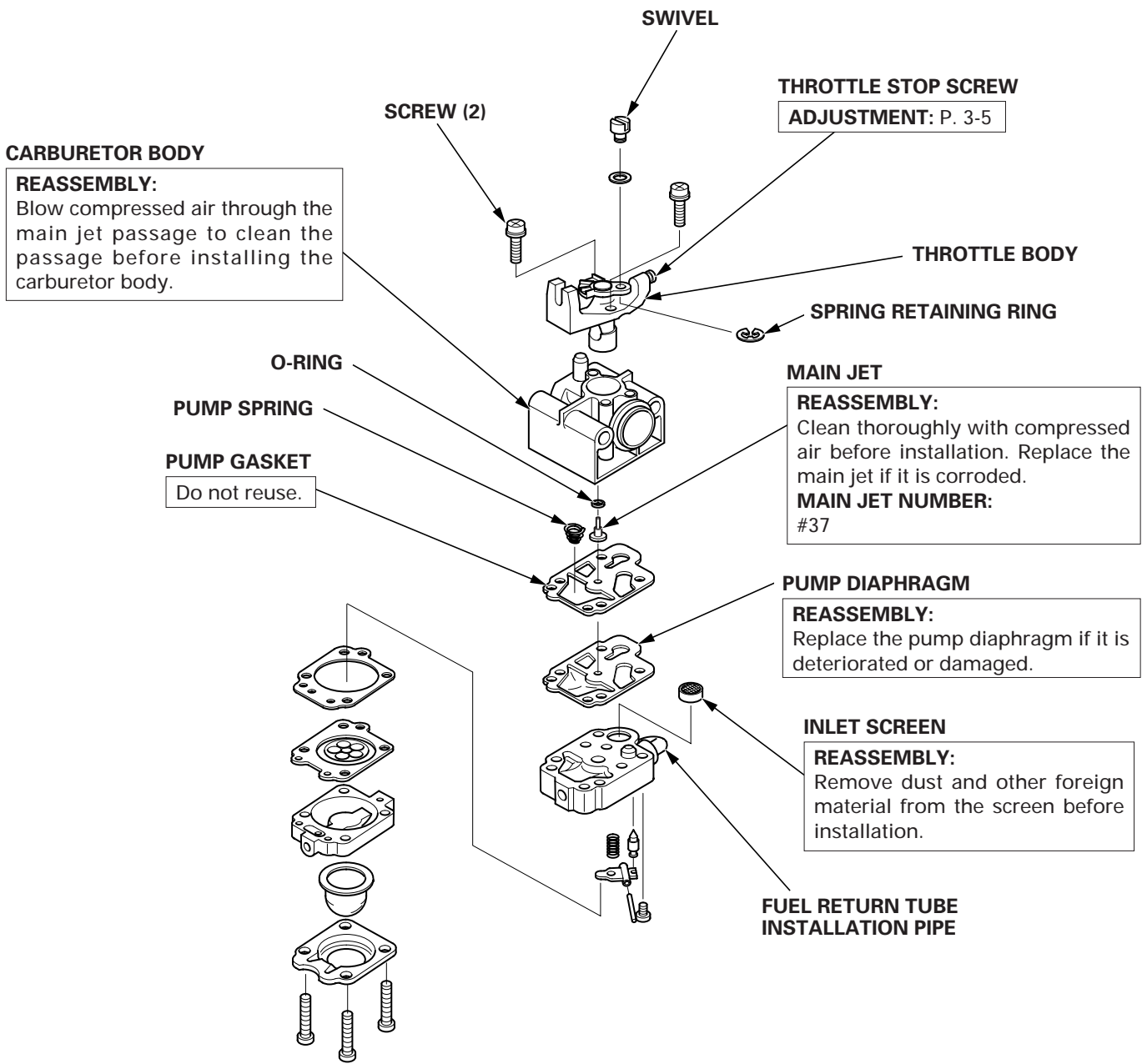

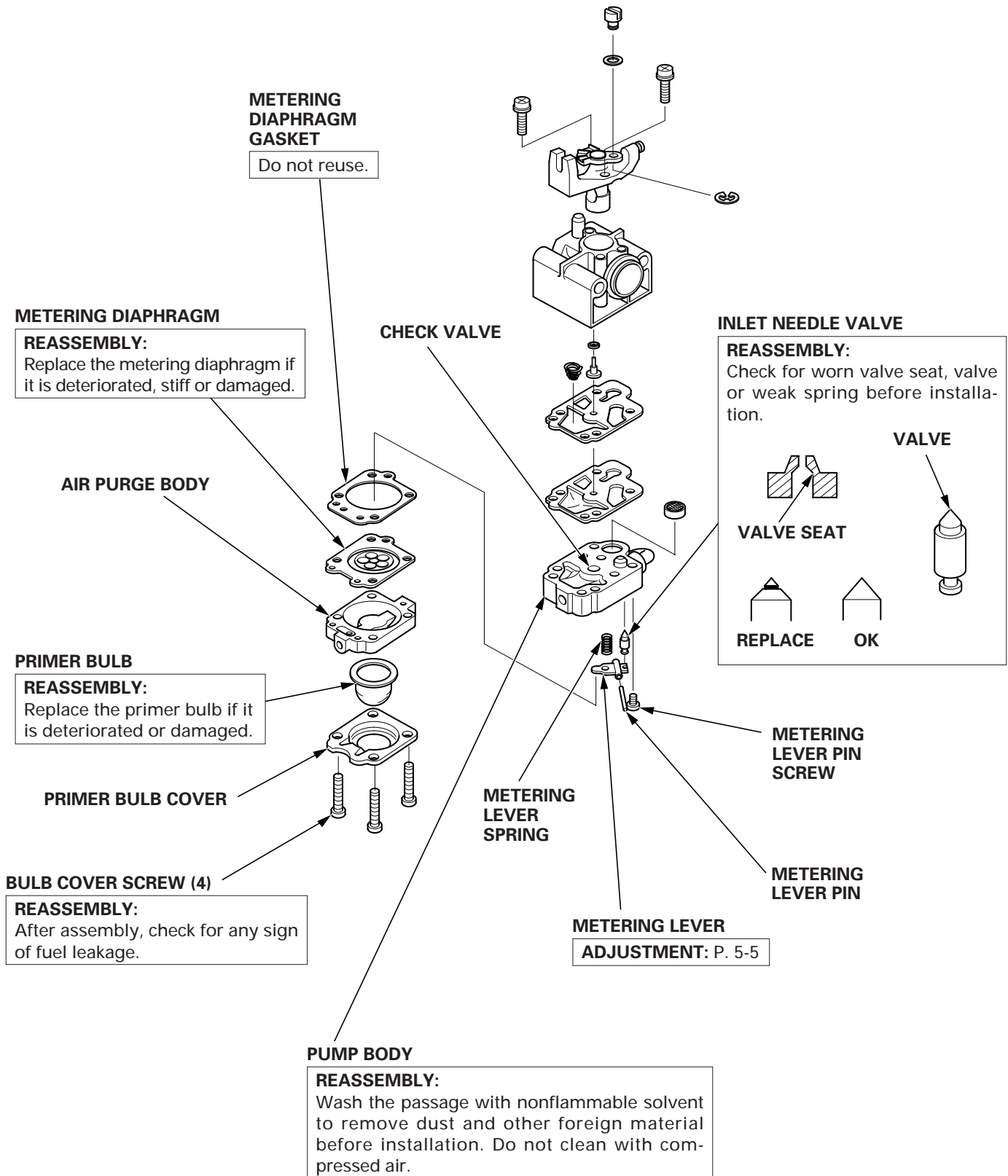

**c. ADJUSTMENT****• Metering lever**

- 1) Install the metering body spring, inlet needle valve, metering lever, metering lever pin and the metering lever pin screw on the pump body (P. 5-4).
- 2) Measure the gap between the metering lever surface and the pump body surface.

Specification	1.18 – 1.50 mm (0.046 – 0.059 in)
---------------	-----------------------------------

- 3) If the measurement is outside the specification, adjust by bending the metering lever.

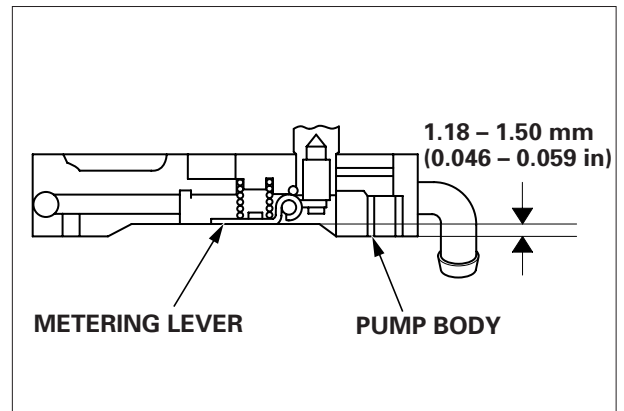

**1. RECOIL STARTER**

**2. FUEL TANK PROTECTOR/FUEL TANK**

## 1. RECOIL STARTER

### a. REMOVAL/INSTALLATION

- 1) Remove the fuel tank protector (SAT type, P. 6-4).

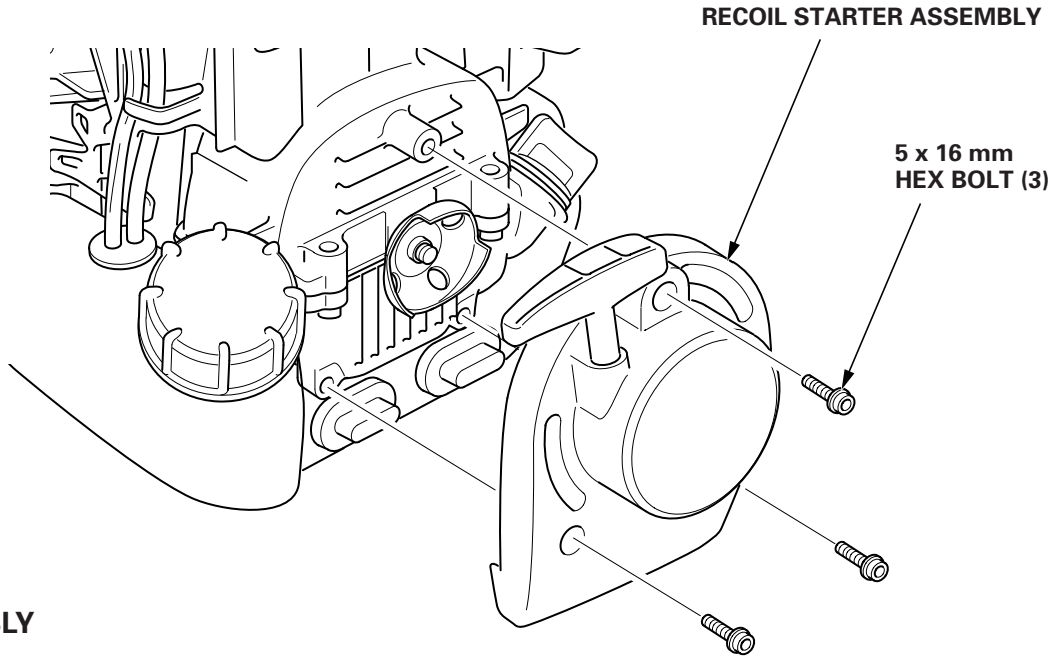

### b. DISASSEMBLY

#### **⚠ WARNING**

- Wear gloves and eye protection.
- During disassembly, take care not to allow the return spring to come out.

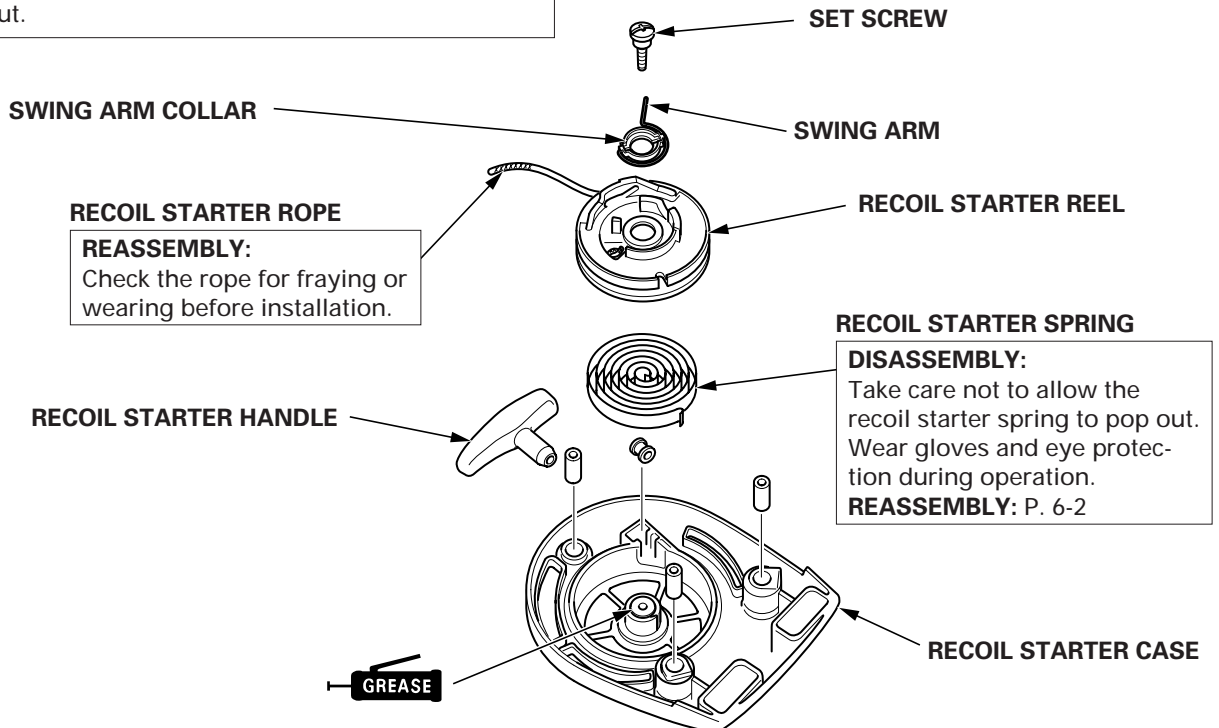

## c. REASSEMBLY

**⚠ WARNING**

- Wear gloves and eye protection.
- During assembly, take care not to allow the return spring to come out.

1) Insert the hook on the outer side of the spring into the groove inside the starter reel. Carefully wind recoil starter spring inside starter reel.

2) Pass the starter rope through the starter reel and tie the rope so that it can be untied easily by pulling it as shown.

Wind the starter rope around the recoil starter reel in the direction of the arrow.

Hook the starter rope into the cutout of the starter reel.

3) Install the starter reel on the starter case so that the spring inner hook is hooked to the case tab.

4) Hold the starter case and rotate the starter reel three turns in the direction of the arrow for preliminary winding.

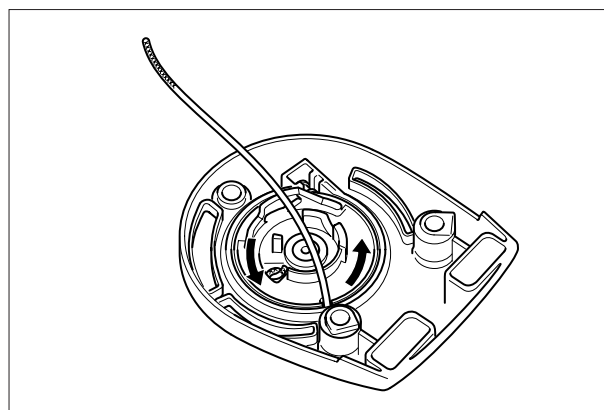
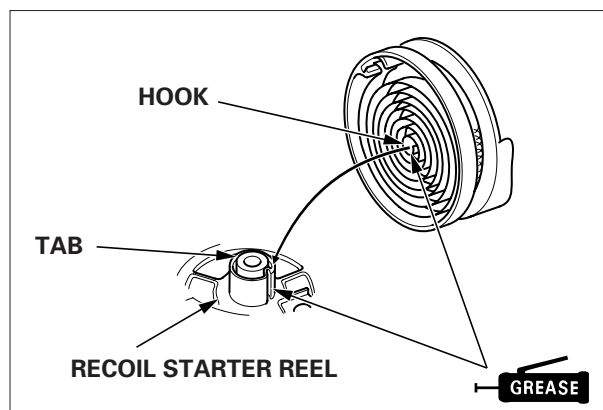
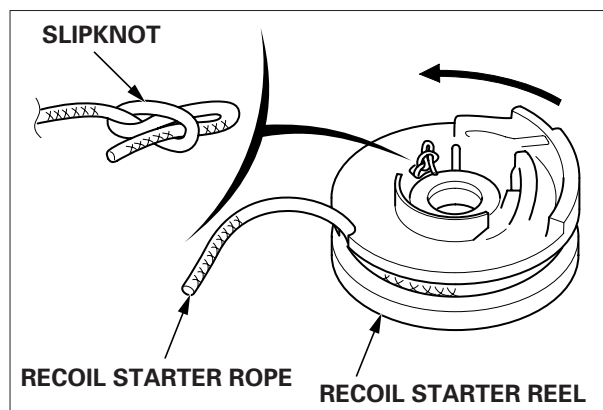
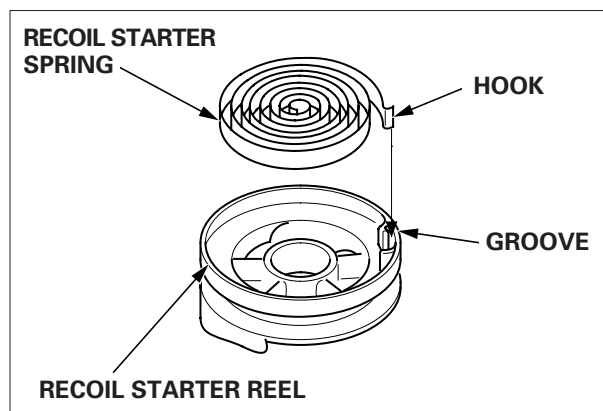

- 5) Unhook the starter rope from the cutout of the starter reel.

Pass the starter rope end through the case and pull it outwards.

Pass the starter rope through the starter handle and tie the rope so that it can be untied easily by pulling it as shown.

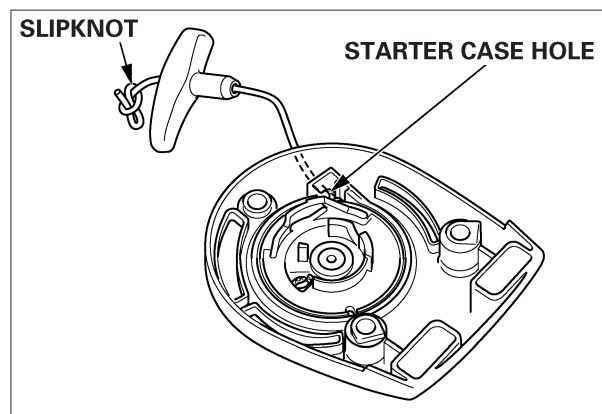

- 6) Secure the starter reel with the set screw.

• Make sure to align the projection of the swing arm collar with swing arm.

- 7) Pull the starter handle several times to make sure the swing arm operates properly.

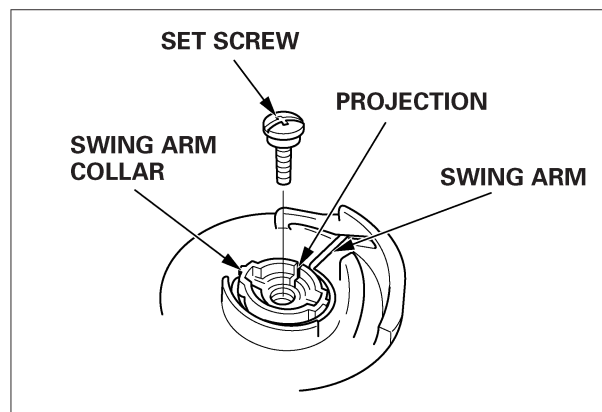



## 2. FUEL TANK PROTECTOR/ FUEL TANK

### a. REMOVAL/INSTALLATION

Before removal, completely drain the fuel tank and fuel line.

#### **⚠ WARNING**

Gasoline is highly flammable and explosive. You can be burned or seriously injured when handling fuel.

- Keep heat, flame, and sparks away.
- Handle fuel only outdoors.
- Wipe up spills immediately.

CUTAWAY VIEW OF A LOW-PERMEABILITY FUEL TANK  
(See page 1-1 for serial numbers)

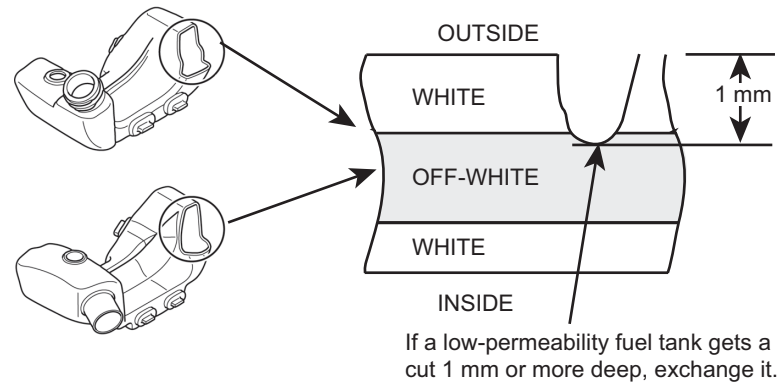

Loosen the fuel tank cap and release the pressure from the tank before operation.

#### FUEL RETURN TUBE (clear)

##### REASSEMBLY:

Inspect for cracks or deterioration before installation and replace if necessary. Verify that the tube is not kinked in the tank.

#### FUEL TUBE (black)

##### REASSEMBLY:

Inspect for cracks or deterioration before installation and replace if necessary. Verify that the tube is not kinked in the tank.

#### FUEL TANK

**FUEL CAPACITY:** See page 1-1

**CLEANING:** P. 3-5

##### REASSEMBLY:

Wash with solvent to remove any solvent, and dry thoroughly before installing.

#### FUEL TUBE GROMMET

##### INSTALLATION:

Insert the fuel tube and fuel return tube into the grommet to the dimensions shown. Note that engine failure can result if the dimensions do not conform to the specifications shown. Take care not to damage the grommet surface where it contacts the tank. Replace the grommet if it is damaged.

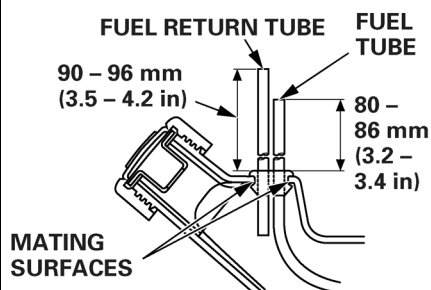

#### FUEL FILTER

**CLEANING:**  
P. 3-6

#### FUEL TANK CAP

#### FUEL TANK PROTECTOR (SAT type)

5 x 16 mm  
HEX BOLT (2)

5 x 30 mm  
HEX BOLT (2)  
(SAT type)

## 1. STARTER PULLEY

## 2. IGNITION COIL/CLUTCH SHOE/FLYWHEEL

### 1. STARTER PULLEY

#### a. DISASSEMBLY/REASSEMBLY

- 1) Remove the top cover (P. 4-1).
- 2) Remove the recoil starter (P. 6-1).
- 3) Remove the fuel tank protector (SAT type) and fuel tank (P. 6-4).
- 4) Remove the fan cover, ignition coil and clutch assembly (P. 7-2).

#### NOTICE

To avoid flywheel fan blade damage, position the strap wrench fulcrum at the flywheel magnetic parts.

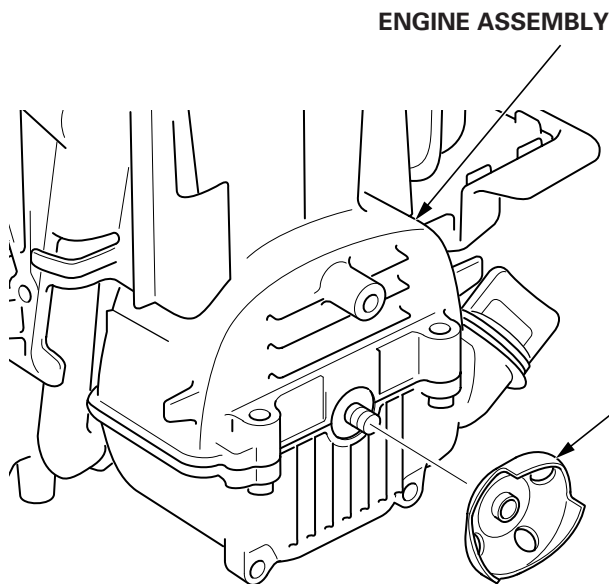

#### RECOIL STARTER PULLEY

##### DISASSEMBLY:

- Remove the ignition coil.
- Remove the fan cover.
- Holding the flywheel with a commercially available strap wrench, remove the recoil starter pulley with a driver or equivalent tool.
- Take care not to damage the fan.

##### STRAP WRENCH (Commercially available)

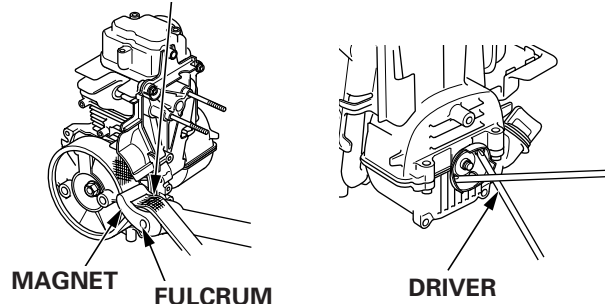

##### REASSEMBLY:

Holding the recoil starter pulley in the same manner as on disassembly, tighten the flywheel to the specified torque.

**TORQUE:** 6.4 N·m (0.65 kgf·m, 4.7 lbf·ft)

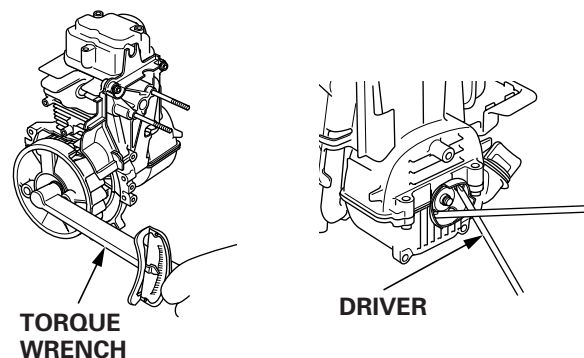

## 2. IGNITION COIL/CLUTCH SHOE/FLYWHEEL

### a. DISASSEMBLY/REASSEMBLY

#### • Ignition coil

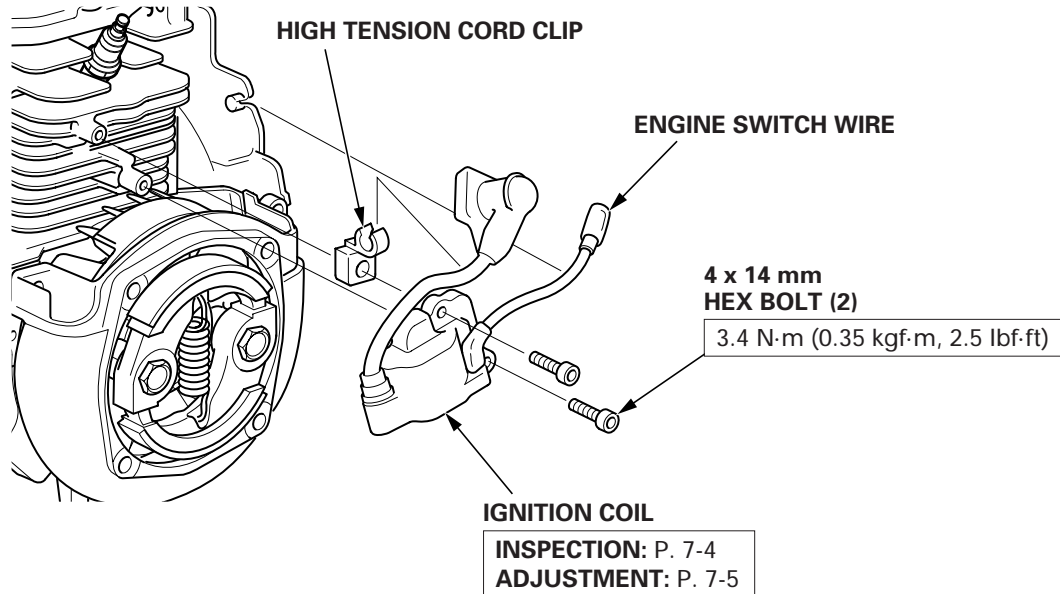

#### • Clutch shoe/Flywheel

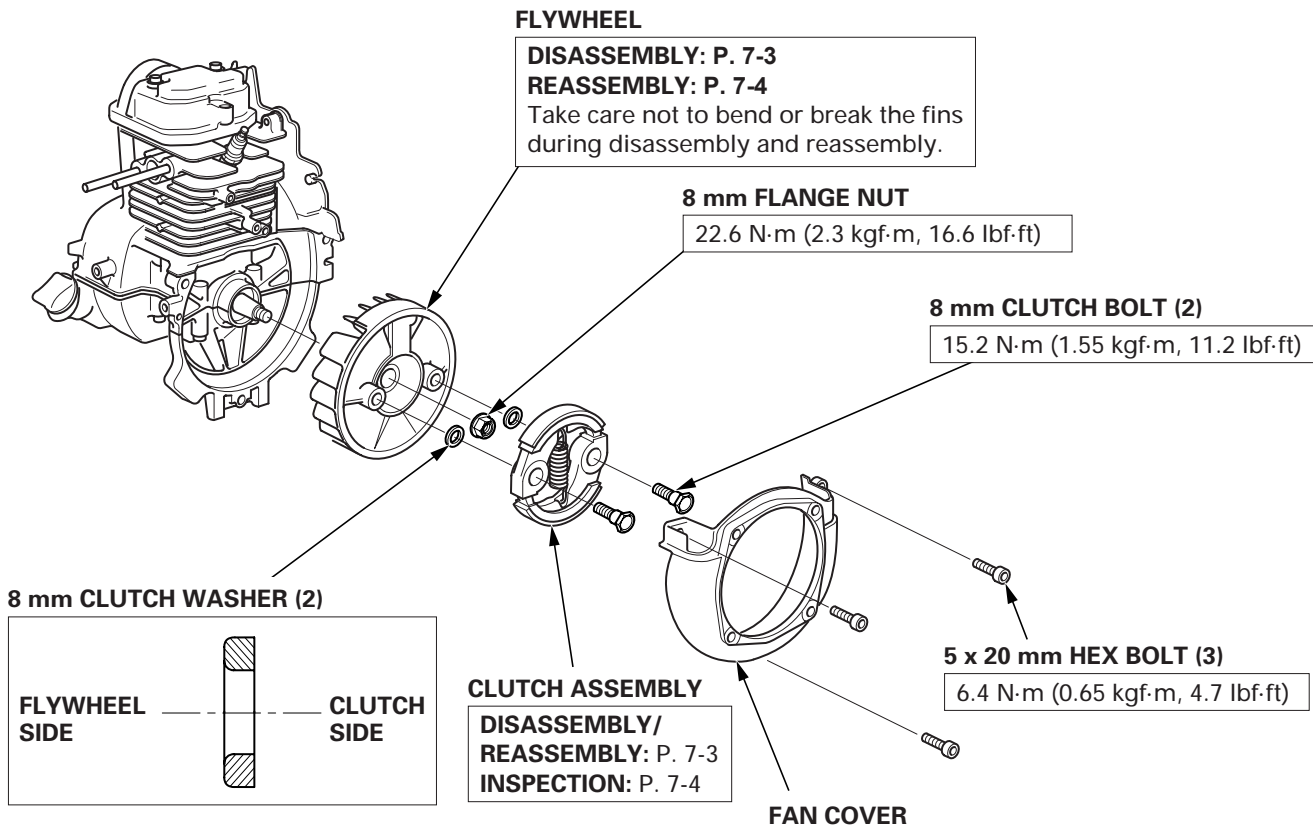

## • CLUTCH ASSEMBLY

### NOTICE

To avoid flywheel fan blade damage, position the strap wrench fulcrum at the flywheel magnetic parts.

### DISASSEMBLY:

Holding the flywheel with a commercially available strap wrench, remove the clutch bolt and remove the clutch assembly.

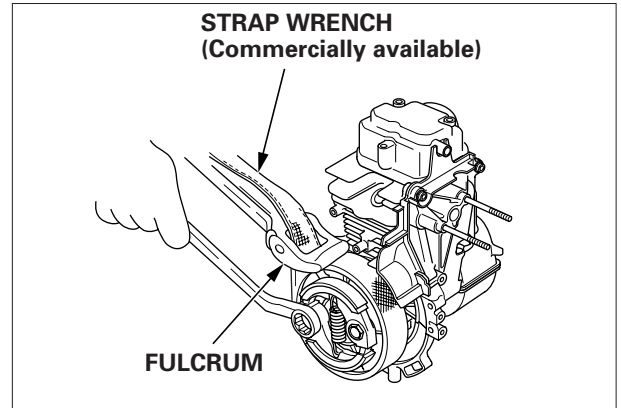

### REASSEMBLY:

- 1) Install the clutch assembly so that "R" mark is visible, as shown.
- 2) Be sure to set the clutch washer between the clutch assembly and flywheel.
- 3) Holding the flywheel with a commercially available strap wrench, tighten the 8 mm clutch bolt to the specified torque.

**TORQUE: 15.2 N·m (1.55 kgf·m, 11.2 lbf·ft)**

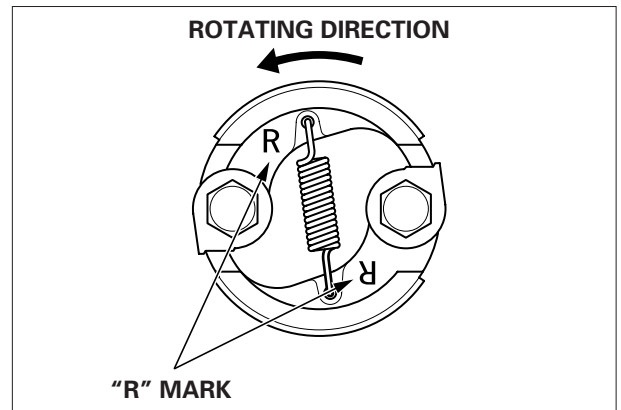

## • FLYWHEEL

### NOTICE

To avoid flywheel fan blade damage, position the strap wrench fulcrum at the flywheel magnetic parts.

### DISASSEMBLY:

- 1) Holding the flywheel with a commercially available strap wrench, remove the 8 mm flange nut from the flywheel.
- 2) Remove the flywheel using a commercially available flywheel puller.

### NOTICE

To avoid damaging the flywheel, do not remove the flywheel by striking it with a hammer.

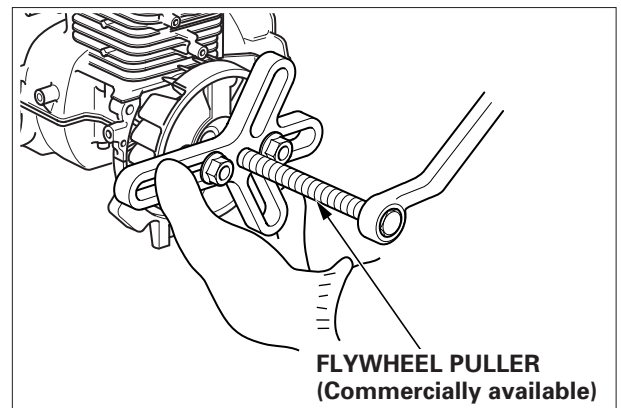
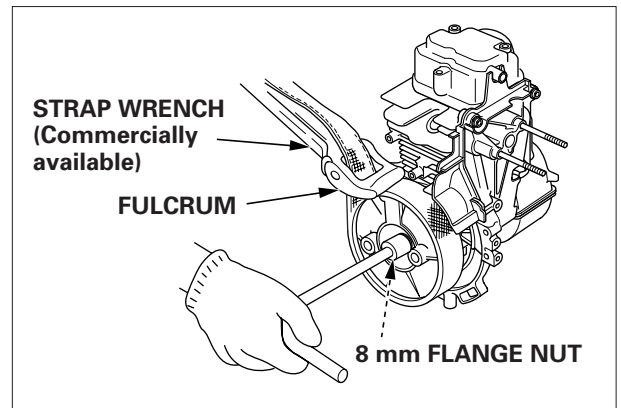

**REASSEMBLY:**

Clean the tapered part of dirt, oil, grease and other foreign material before installation.

- 1) Be sure that the woodruff key is set in the key groove properly.
- 2) Holding the flywheel with a commercially available strap wrench, tighten the 8 mm flange nut to the specified torque.

**TORQUE: 22.6 N·m (2.3 kgf·m, 16.6 lbf·ft)**

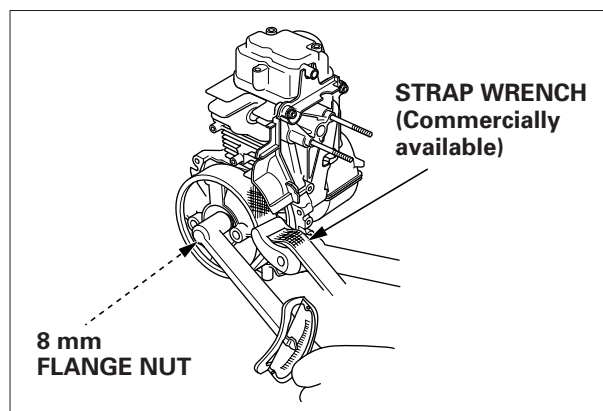

**b. INSPECTION**

**• IGNITION COIL**

**<Primary resistance>**

Attach one lead of the tester to the lead terminal and another tester lead to the iron core, and measure the primary resistance of the ignition coil.

Resistance	0.75 – 0.92 Ω
------------	---------------

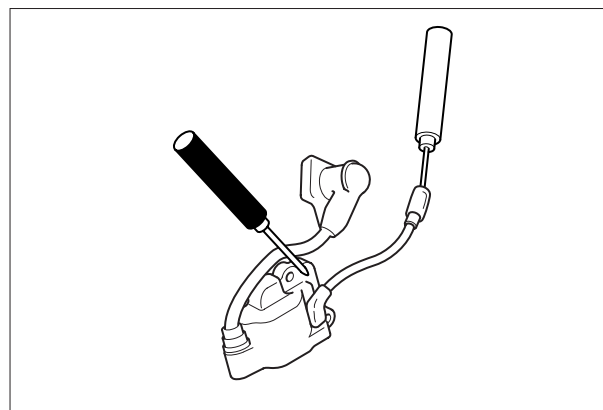

**<Secondary resistance>**

Attach one lead of the tester to the terminal inside the spark plug cap and another lead to the iron core, and measure the secondary resistance of the ignition coil.

Resistance	6.1 – 9.3 kΩ
------------	--------------

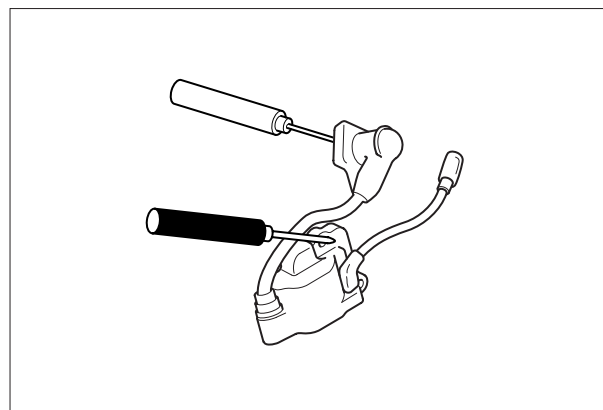

**• CLUTCH ASSEMBLY**

Measure the thickness at the center of the clutch lining.

Standard	Service limit
2.0 mm (0.08 in)	1.0 mm (0.04 in)

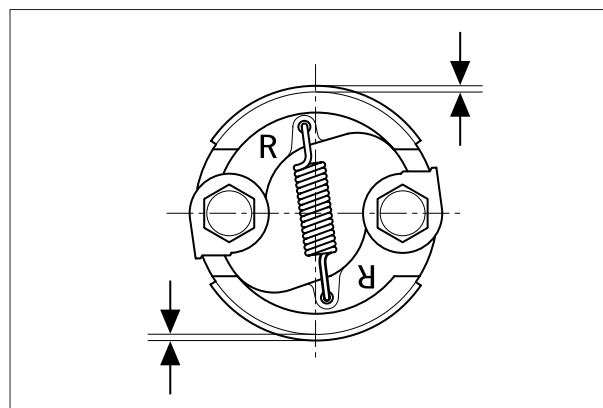

**c. ADJUSTMENT****• IGNITION COIL AIR GAP**

Adjustment is required only when the ignition coil or the flywheel has been removed.

- 1) Loosen the ignition coil bolts.  
Insert a feeler gauge between the ignition coil and the magnetic part of the flywheel.

- 2) Push the ignition coil firmly toward the flywheel and tighten the bolts.

Specified clearance	0.2 – 0.4 mm (0.008 – 0.016 in)
---------------------	---------------------------------

- Adjust the clearance at the magnetic part of the flywheel.
- Adjust both gaps at the right and left sides of the ignition coil simultaneously so they are equal.

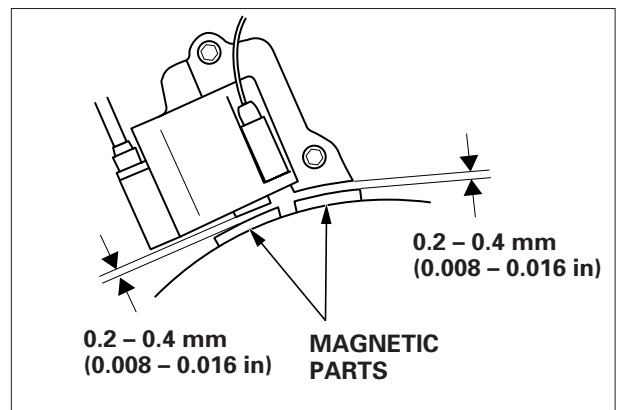
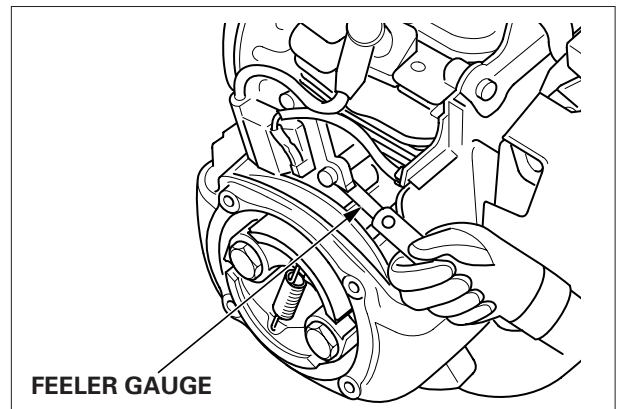

**1. CAM PULLEY/CYLINDER HEAD COVER**

**2. LOWER CRANKCASE**

**1. CAM PULLEY/CYLINDER HEAD COVER**

**a. DISASSEMBLY/REASSEMBLY**

- 1) Remove the top cover (P. 4-1).
- 2) Remove the fan cover (P. 7-2).

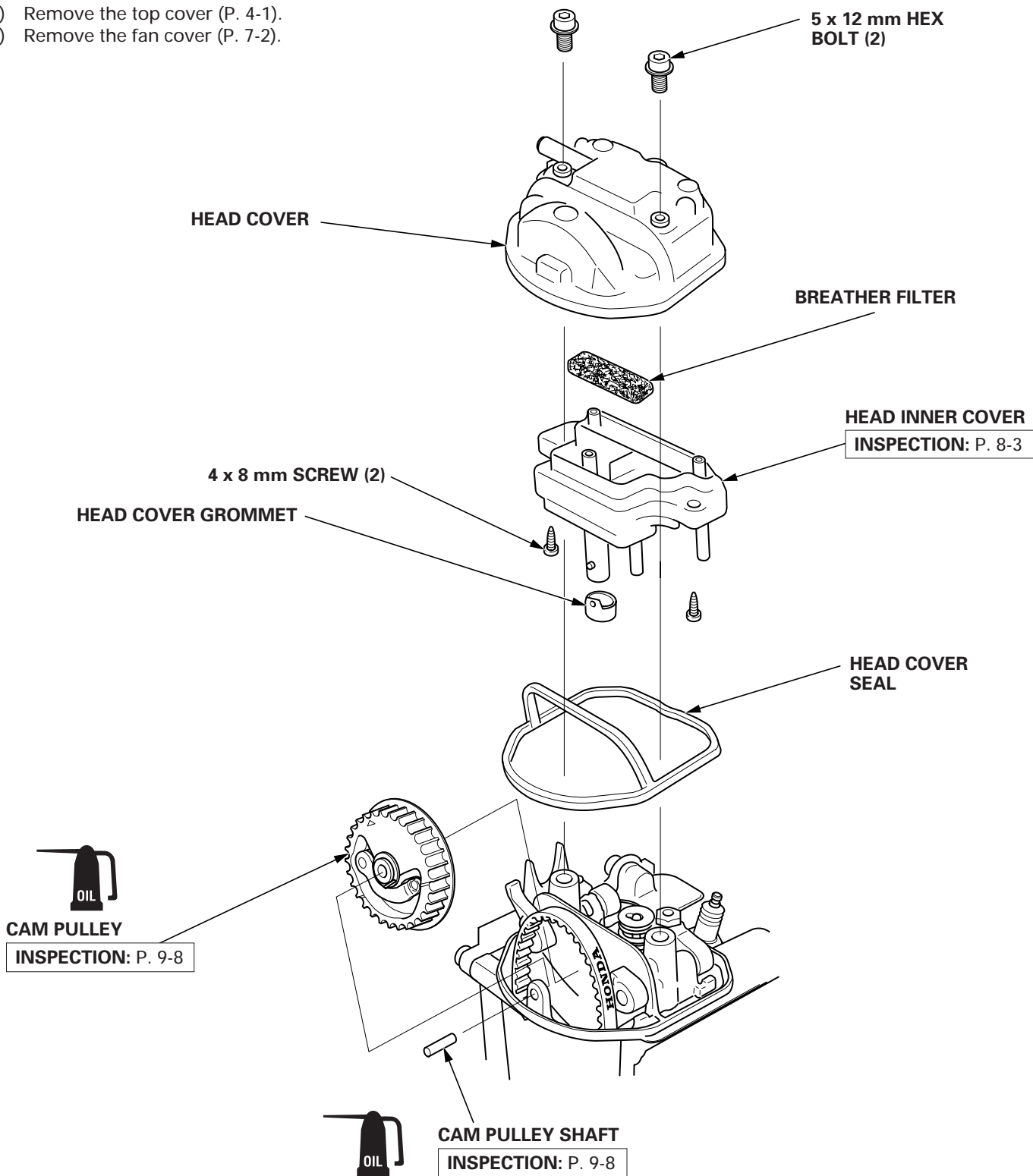

• **CAM PULLEY**

**REMOVAL:**

- 1) Remove the spark plug, and head cover (P. 3-3, P. 8-1).
- 2) Set the piston at top dead center (TDC) of the compression stroke.

When the piston is at TDC of the compression stroke, the flywheel alignment mark "▽" will align with the fan cover bolt hole. Also, the cam pulley alignment marks will be positioned as shown.

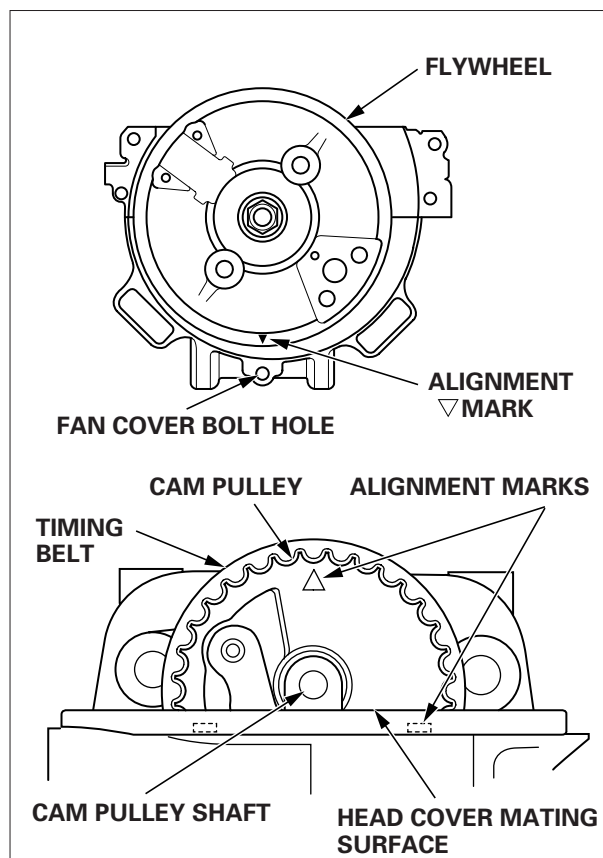

- 3) Push the cam pulley shaft out from the valve spring side using a pin approximately 2 mm in diameter.

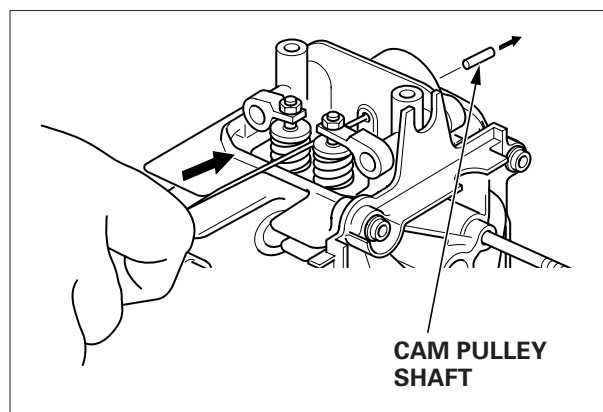

- 4) Remove the timing belt from the cam pulley, and remove the cam pulley.

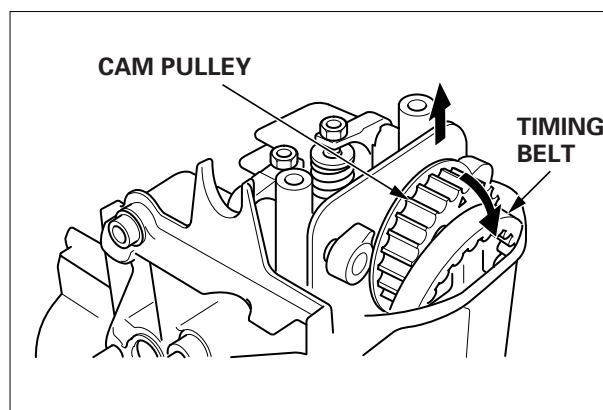



## • CYLINDER HEAD INNER COVER

### INSPECTION:

#### <Oil passage>

Check the oil return passages of the cylinder head inner cover for restrictions. If they are restricted, clean with compressed air.

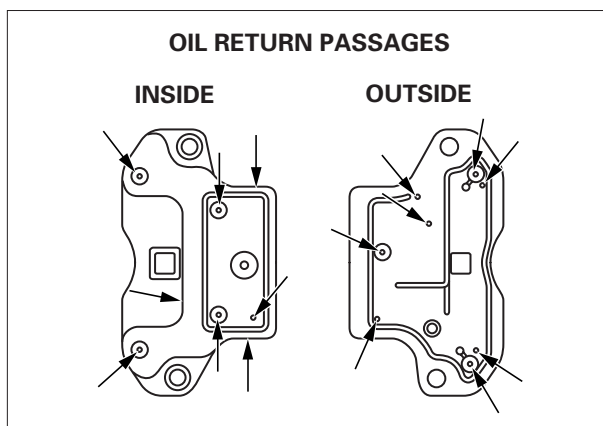

## 2. LOWER CRANKCASE

### a. DISASSEMBLY/REASSEMBLY

- 1) Drain the engine oil (P. 3-2).
- 2) Remove the air cleaner case assembly and carburetor (P. 5-1 and 2).
- 3) Remove the recoil starter (P. 6-1), fuel tank protector (SAT type) and fuel tank (P. 6-4).
- 4) Remove the muffler (P. 4-1).
- 5) Remove the recoil starter pulley and flywheel (P. 7-1 and 2).

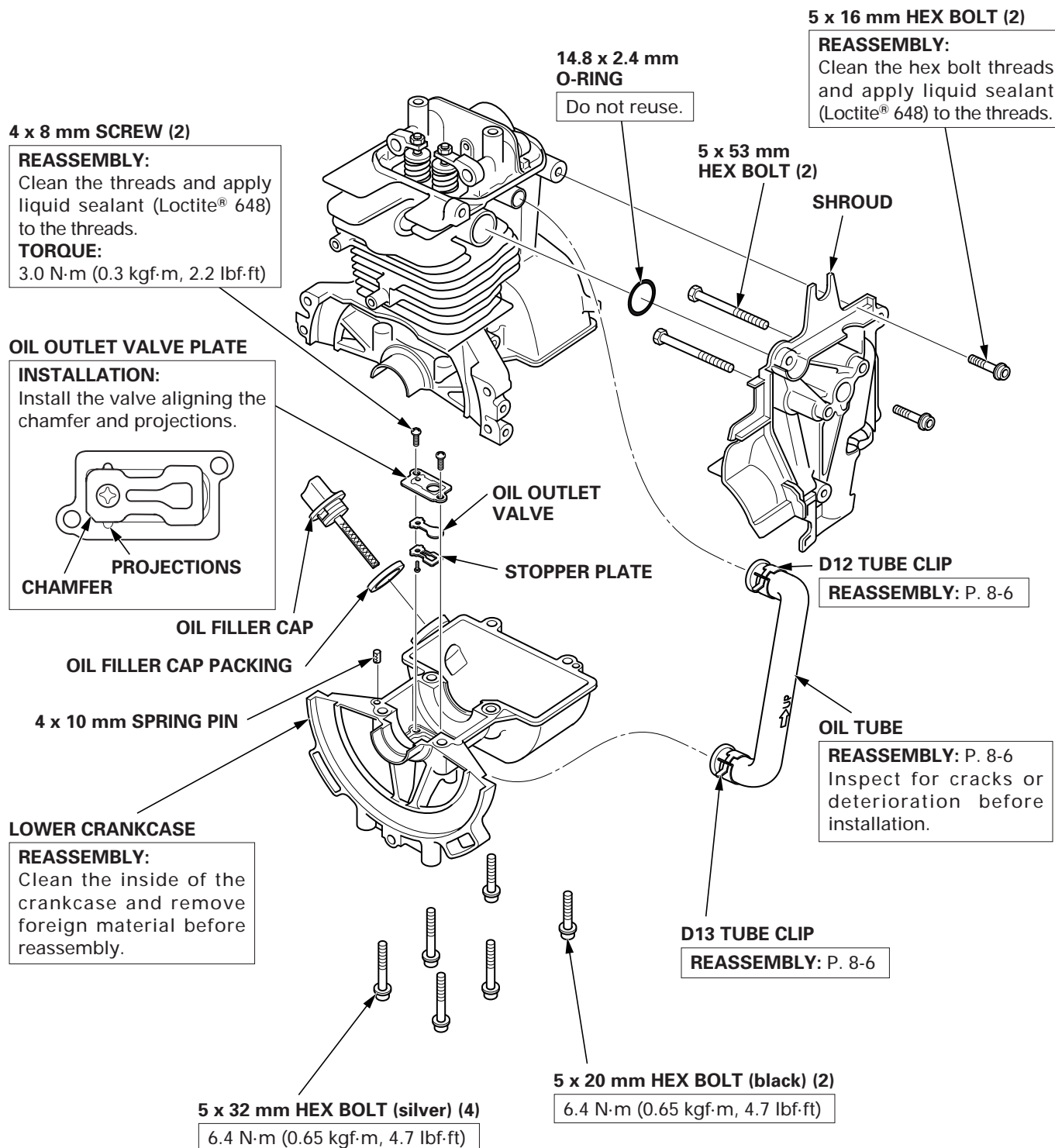

## • LOWER CRANKCASE

### REMOVAL:

- 1) Remove the two 5 x 20 mm and four 5 x 30 mm hex bolts.
- 2) Insert a screw driver or equivalent tool into the recess as shown, and remove the lower crankcase from the cylinder block.

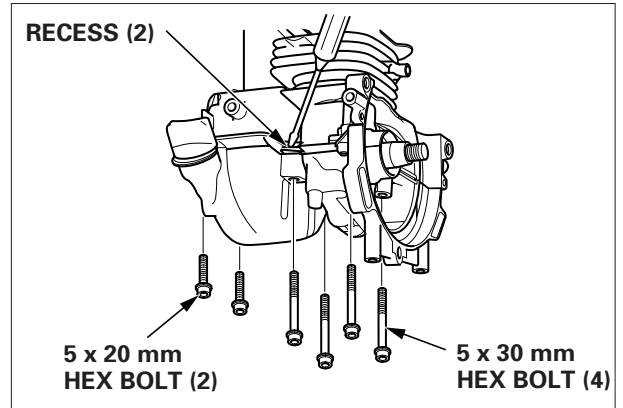

### INSTALLATION:

- 1) Clean the mating surfaces of the cylinder block and the lower crankcase using a degreasing cleaning agent and clean shop towel.
- 2) Apply a bead [ $\varnothing 1.0 - 1.5$  mm ( $\varnothing 0.04 - 0.06$  in)] of liquid gasket (Hondabond 4, ThreeBond® #1216, 1216E or equivalent) to the cylinder block; specifically, to the mating surface with the lower crankcase.
- 3) Install the lower crankcase on the cylinder block. Assemble within 3 minutes after applying the liquid gasket.
- 4) Loosely tighten each two 5 x 20 mm and four 5 x 30 mm hex bolts then tighten to the numbered sequence.

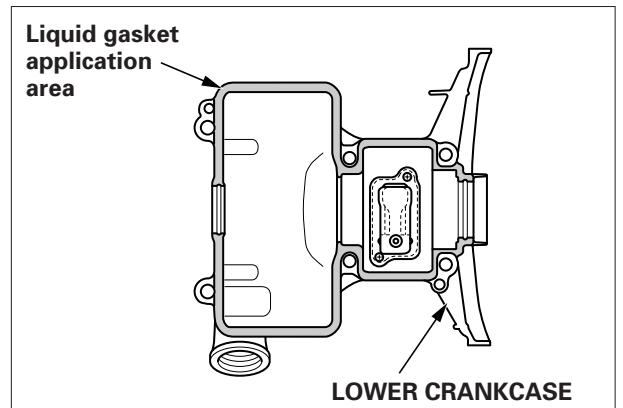

**TORQUE: 6.4 N·m (0.65 kgf·m, 4.7 lbf·ft)**

- 5) Wait for approximately 60 minutes after assembly before adding oil and starting the engine.

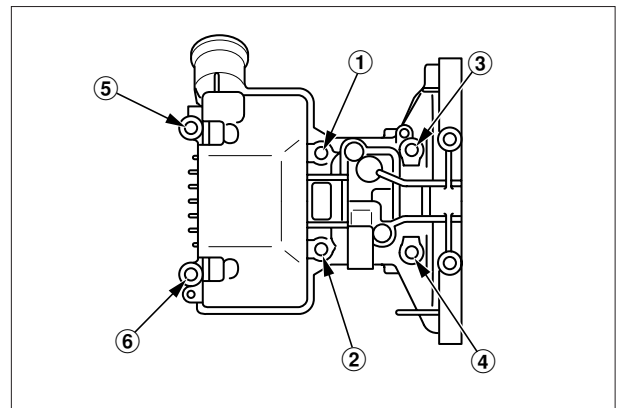

## • OIL OUTLET VALVE

### DISASSEMBLY:

- 1) Remove the two 4 x 8 mm screws and oil outlet valve assembly.

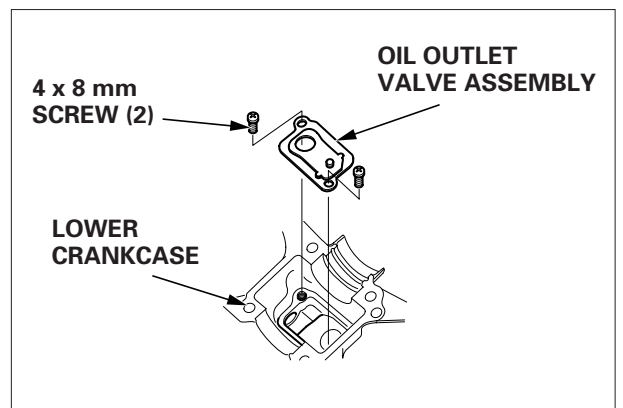

- 2) Remove the 3 x 5 mm screw, stopper plate, oil outlet valve and oil outlet valve plate.  
Check the oil outlet valve and stopper plate for contamination and foreign material.

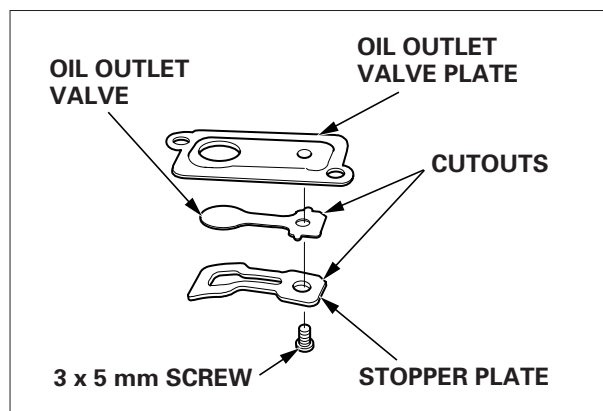

**• SHROUD**

**REASSEMBLY:**

Set the 5 x 53 mm hex bolts on the shroud. Take care not to allow the bolt heads to protrude from the shroud when installing on the cylinder block.

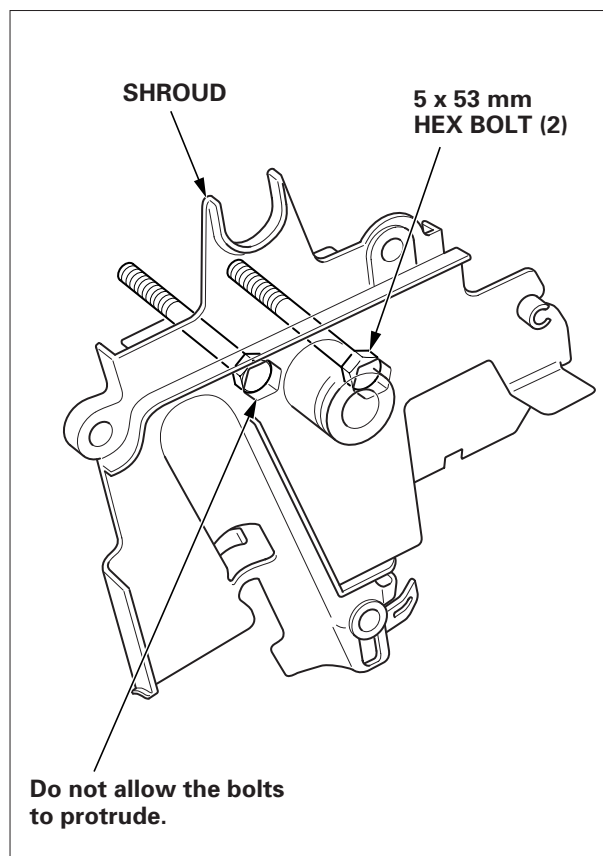

**• OIL TUBE**

**REASSEMBLY:**

- 1) Install the oil tube with the "⇒UP" mark facing toward the cylinder.
- 2) Install the D12 and D13 tube clips as shown.

**NOTICE**

- If the clips are interchanged, oil may leak resulting in engine failure. Do not interchange the clips.
- Be sure that the tube and the shroud do not come into contact.

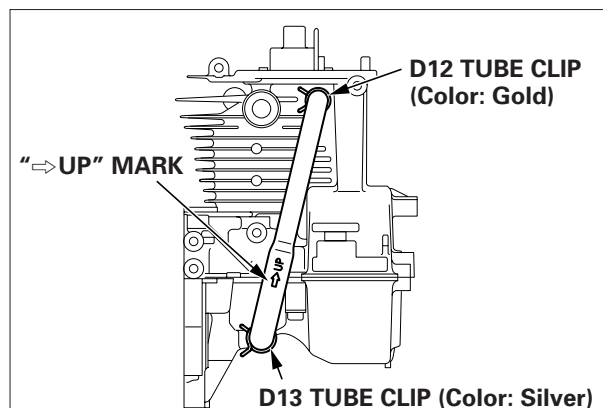

- 1. CRANKSHAFT/PISTON
- 2. CYLINDER BLOCK/VALVES

- 3. INSPECTION
- 4. ROCKER ARM/VALVE LIFTER

**1. CRANKSHAFT/PISTON**

**a. DISASSEMBLY/REASSEMBLY**

Remove the lower crankcase (P. 8-5).

**PISTON RING**

**INSPECTION:** P. 9-6 and 7

**REASSEMBLY:**

- Install the second ring with the "•" or "R" mark facing up.
- Do not interchange the top ring and the second ring.
- After assembly, check for smooth movement of the piston ring.
- Stagger the piston ring end gaps 120° apart, Do not align with the piston pin.
- Space the side rail end gaps at least 10 mm (0.4 in) apart. Coat the rings with oil after assembly.

**TOP RING**

(WHITE CIRCUMFERENCE)

**SECOND RING**

(BLACK CIRCUMFERENCE)

**OIL RINGS (COMBINATION RINGS)**

SIDE RAIL  
SPACER  
SIDE RAIL

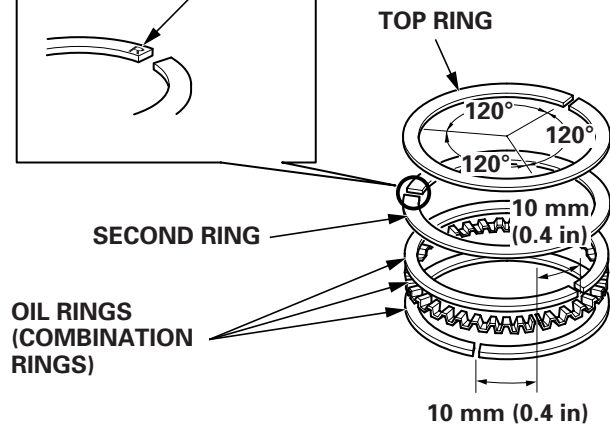
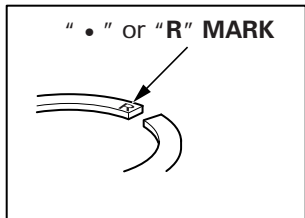

**TIMING BELT**

**INSTALLATION:** P. 9-4

Check that the belt is not worn or cracked. Do not bend or twist the belt.

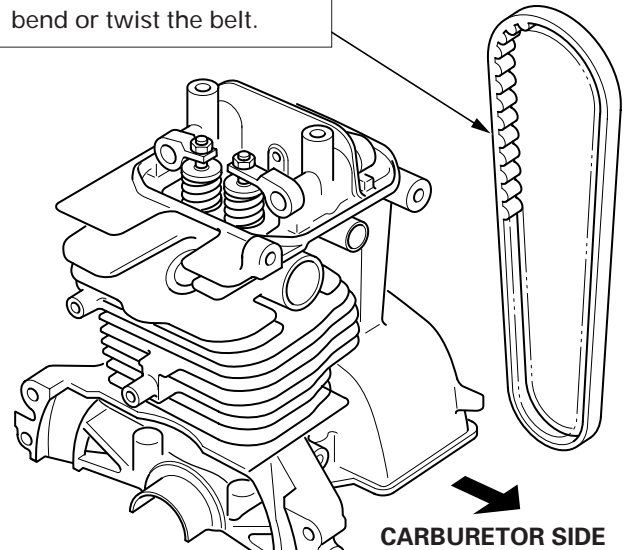

**PISTON PIN**

**DISASSEMBLY/REASSEMBLY:** P. 9-2

**INSPECTION:** P. 9-7

**PISTON**

**INSPECTION:** P. 9-6 and 7

**REASSEMBLY:** Install with the "△" mark on the piston head facing the carburetor side.

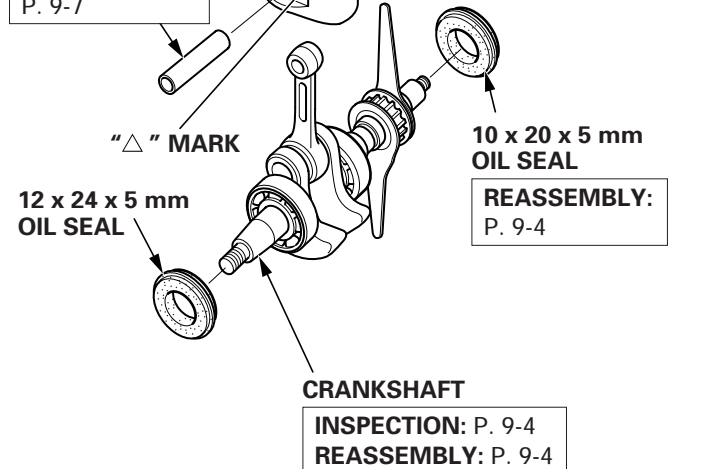

**• PISTON PIN**

**DISASSEMBLY:**

- 1) Insert the push rod special tool into the piston pin with the crankshaft timing belt drive pulley upward as shown.

**TOOL:**

Push rod

**07VPF-ZM3020A**

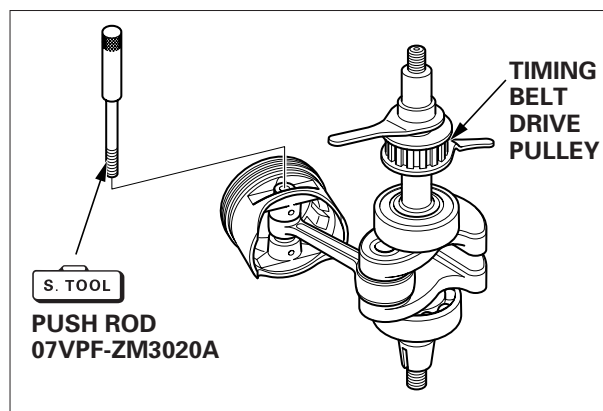

- 2) Set the cutout part of the piston base special tool in the clearance between the connecting rod and the piston as shown.

- Be sure that the connecting rod small end is securely set in the cutout of the piston base special tool.

- 3) Remove the piston pin from the connecting rod using a hydraulic press.

**TOOLS:**

Piston base  
Push rod

**07VPF-ZM3010B  
07VPF-ZM3020A**

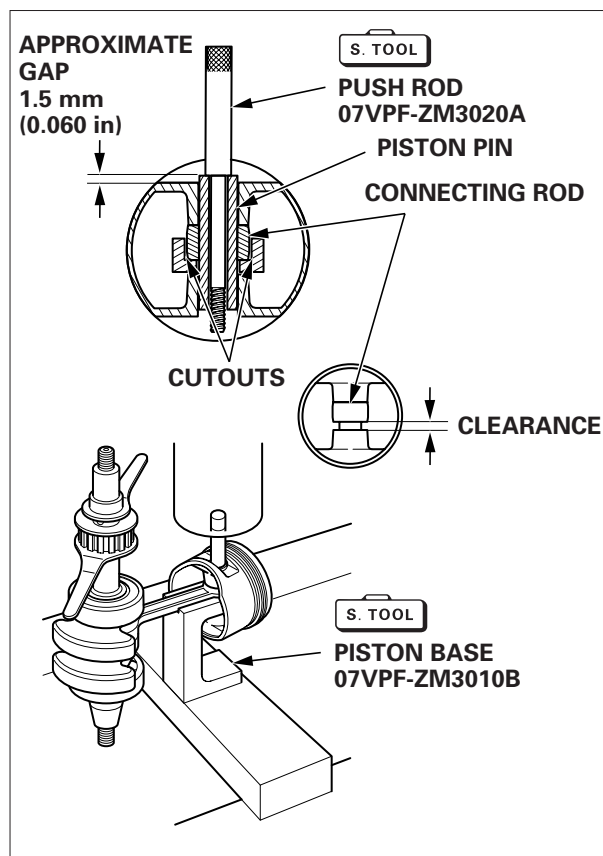

**REASSEMBLY:**

- 1) Slide the piston pin over the push rod special tool, and install the guide special tool.

**TOOLS:**

Push rod  
Guide

**07VPF-ZM3020A  
07VPF-ZM3030A**

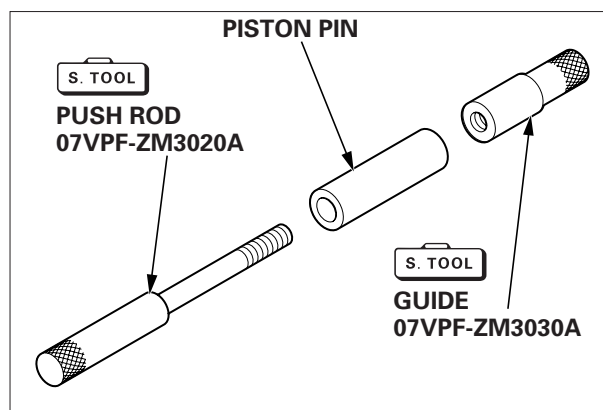

- 2) Set the piston over the connecting rod so that the crankshaft oil slinger is on the right side with the "△" mark on the piston head pointing toward you as shown.

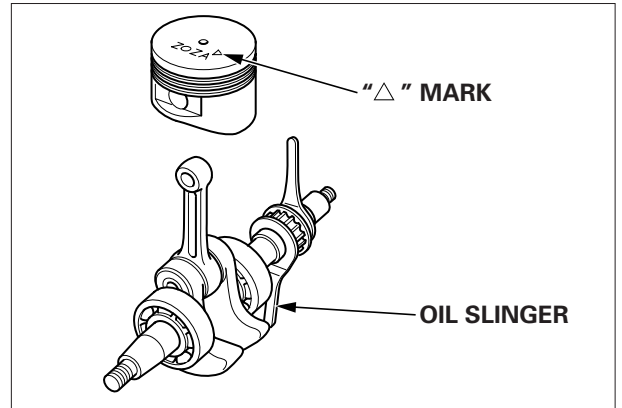

- 3) Apply oil to the piston pin and assemble the piston pin with the special tools attached as shown.

With the timing belt drive gear up, align the piston pin hole with the connecting rod hole and insert the special tool guide into the piston pin hole.

- 4) Set the cutout part of the piston base special tool in the clearance between the connecting rod and the piston as shown.

- Be sure that the connecting rod small end is securely set in the cutout of the piston base special tool.

- 5) Use a hydraulic press to press the piston pin into the connecting rod until the piston pin extends approximately 1.5 mm above the piston.

- 6) Remove the special tools from the piston pin.

**TOOLS:**  
**Piston base** 07VPF-ZM3010B  
**Push rod** 07VPF-ZM3020A  
**Guide** 07VPF-ZM3030A

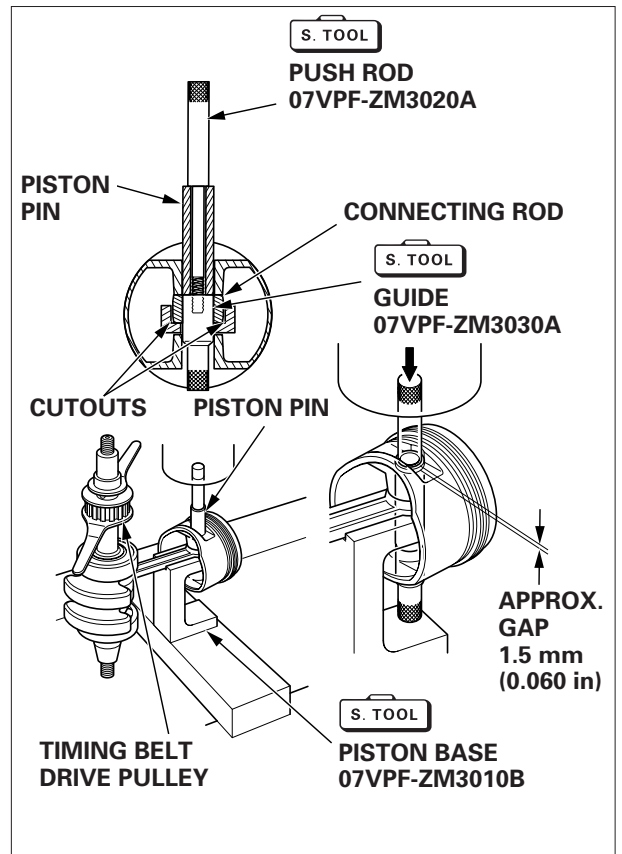

- 7) After assembling the piston pin, move the connecting rod from side to side and make sure the gap from the piston pin end to the piston end is equal at the right and left sides.

- 8) If the right and left gaps are not equal, raise or lower piston pin as needed.

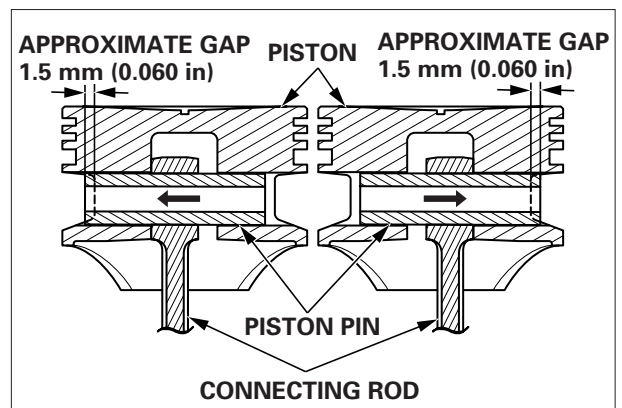

**• CRANKSHAFT**

**INSPECTION:**

Check the oil slinger of the crankshaft for damage and deformation. Replace the crankshaft if it is damaged or deformed.

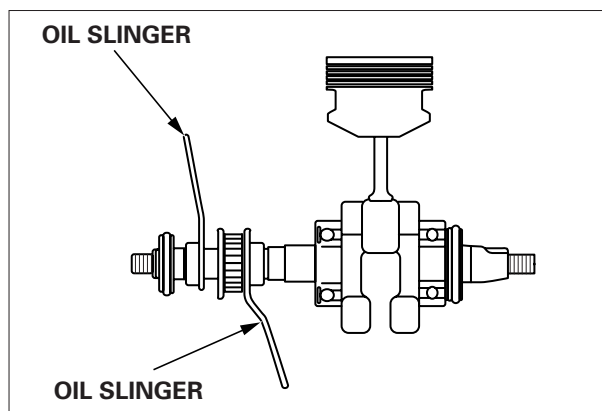

**REASSEMBLY:**

- 1) Install the timing belt on the timing gear crankshaft. When installing, pay attention to the direction of the letter on the timing belt as shown in the picture.
  - Replace worn or cracked timing belt. Do not bend or twist the timing belt.
- 2) Install the crankshaft in the cylinder block.
- 3) Apply a bead of liquid gasket to the cylinder block; specifically to the mating surface of the crankcase cover. Install the crankcase cover on the cylinder block (P. 8-5).
- 4) Install the cam pulley and timing belt in the cam pulley and cylinder block (P. 8-2).

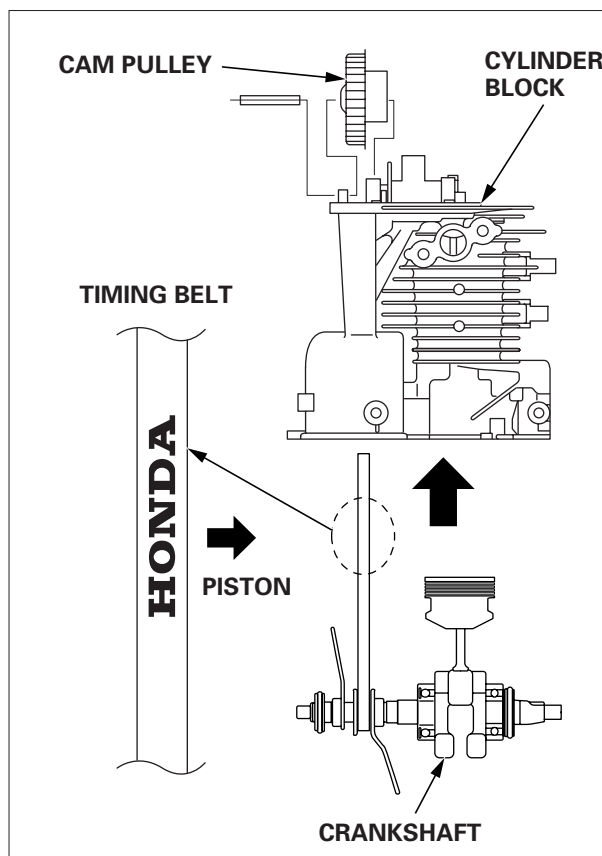

**• 10 x 20 x 5 mm OIL SEAL**

**REASSEMBLY:**

- 1) Set the oil seal on the crankshaft.
- 2) Install by aligning the oil seal projection with the groove in the cylinder block.
- 3) Install the lower crankcase (P. 8-5).

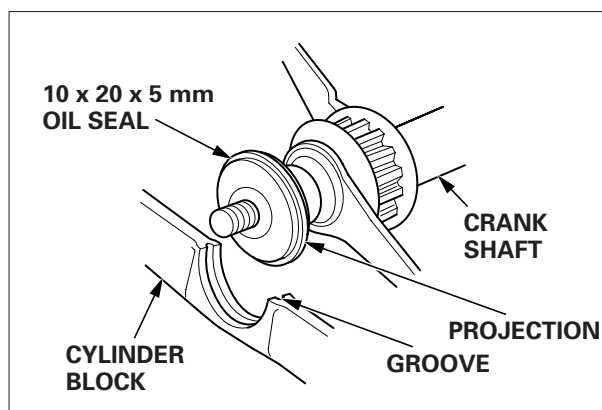



**2. CYLINDER BLOCK/VALVES**

**a. DISASSEMBLY/REASSEMBLY**

1. Remove the head cover and cam pulley (P. 8-1).
2. Remove the lower crankcase (P. 8-5).
3. Remove the crankshaft (P. 9-1).

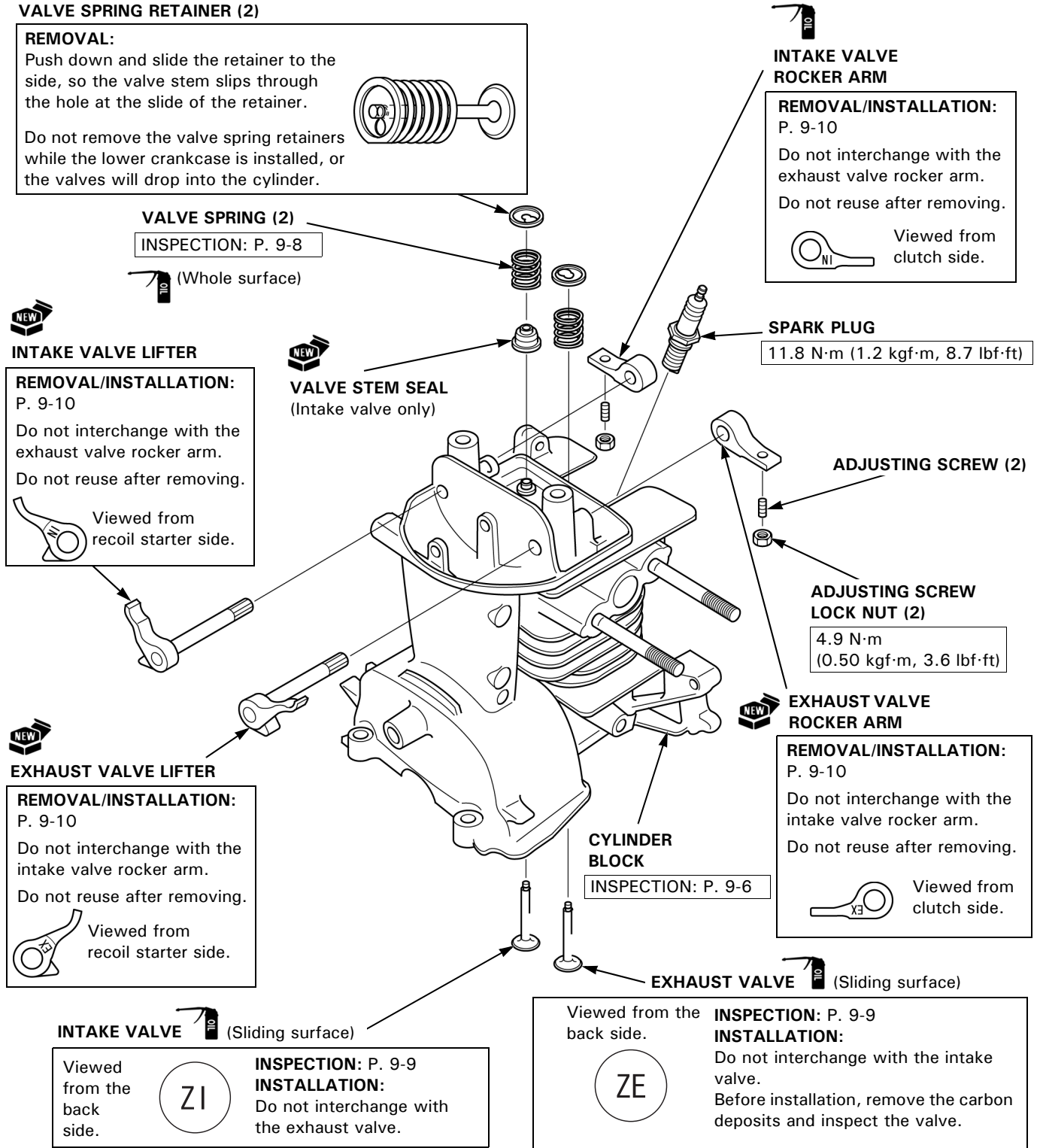

### 3 INSPECTION

#### • CYLINDER SLEEVE I.D.

Measure and record the cylinder I.D. at three levels in both the " X " axis (perpendicular to crankshaft) and the " Y " axis (parallel to crankshaft). Take the maximum reading to determine cylinder wear and taper.

Standard	Service limit
39.000 – 39.015 mm (1.535 – 1.536 in)	39.100 mm (1.5393 in)

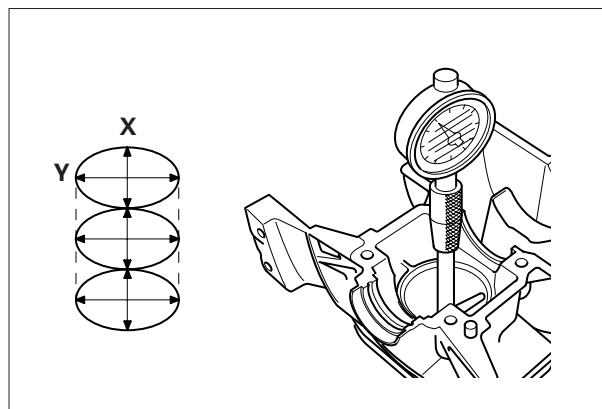

#### • PISTON SKIRT O.D.

Measure and record the piston O.D. at a point 10 mm (0.39 in) from the bottom of the skirt and 90° to the piston pin bore.

Standard	Service limit
38.970 – 38.990 mm (1.534 – 1.535 in)	38.900 mm (1.5314 in)

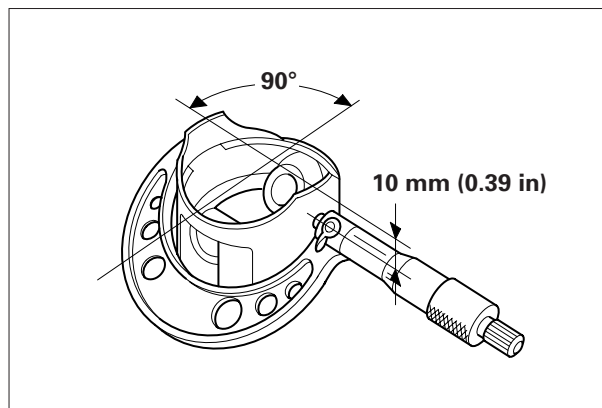

#### • PISTON-TO-CYLINDER CLEARANCE

Standard	Service limit
0.010 – 0.045 mm (0.0004 – 0.0018 in)	0.120 mm (0.0047 in)

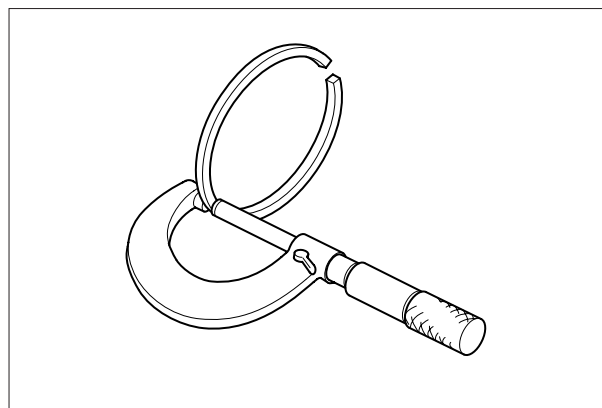

#### • PISTON RING WIDTH

	Standard	Service limit
Top/Second	0.970 – 0.990 mm (0.0382 – 0.0390 in)	0.920 mm (0.0362 in)

#### • PISTON RING SIDE CLEARANCE

	Standard	Service limit
Top/Second	0.015 – 0.056 mm (0.0006 – 0.0022 in)	0.120 mm (0.0047 in)

When any piston ring exceeds the service limit, replace all the piston rings as a set.

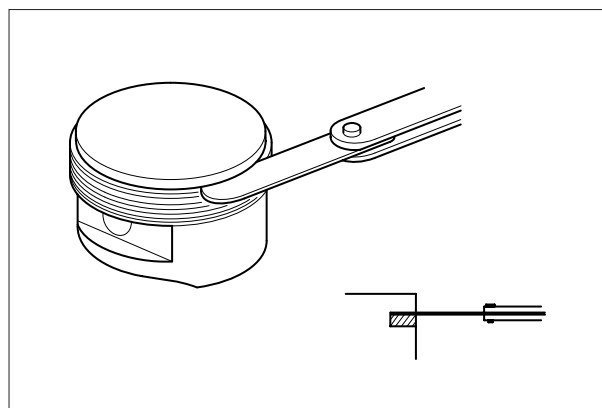

## • PISTON RING END GAP

Put the piston ring in the cylinder and then use the piston crown to push the ring down. This will make the piston ring horizontal so ring end gap can be measured.

	Standard	Service limit
Top/Second	0.10 – 0.25 mm (0.004 – 0.010 in)	0.60 mm (0.024 in)

Because the combination oil rings are used on this model, always replace piston rings as a set.

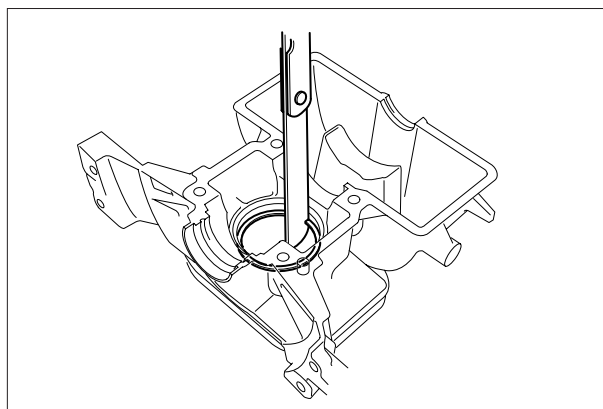

## • PISTON PIN O.D.

Standard	Service limit
7.994 – 8.000 mm (0.3147 – 0.3150 in)	7.950 mm (0.3130 in)

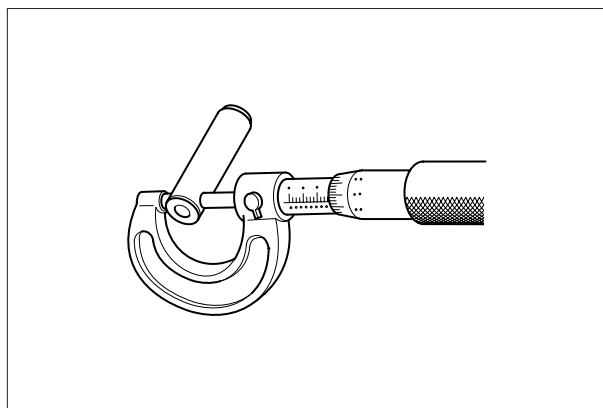

## • PISTON PIN BORE I.D.

Standard	Service limit
8.010 – 8.026 mm (0.3154 – 0.3160 in)	8.060 mm (0.3173 in)

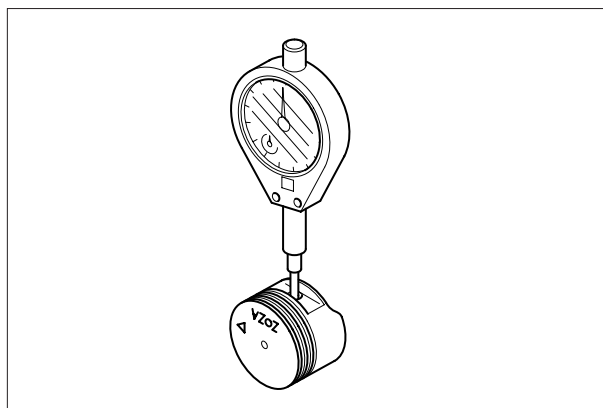

## • PISTON PIN-TO-PIN BORE CLEARANCE

Standard	Service limit
0.010 – 0.032 mm (0.0004 – 0.0013 in)	0.070 mm (0.0028 in)

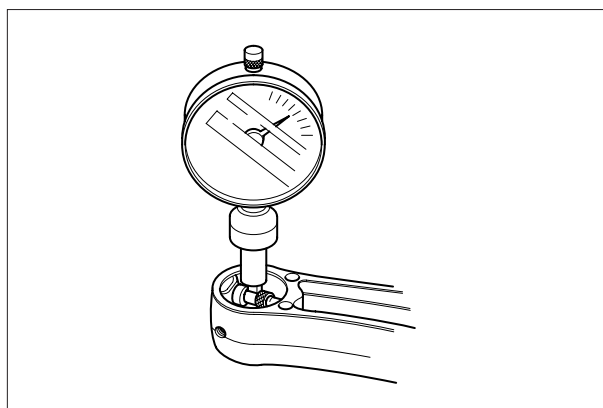

## • CONNECTING ROD SMALL END I.D.

Standard	Service limit
7.978 – 7.989 mm (0.3141 – 0.3145 in)	Replace if exceeding the standard value.

**• CAM HEIGHT**

Standard	Service limit
22.46 mm (0.884 in)	22.16 mm (0.8724 in)

Replace the cam if the cam height is lower than the service limit.

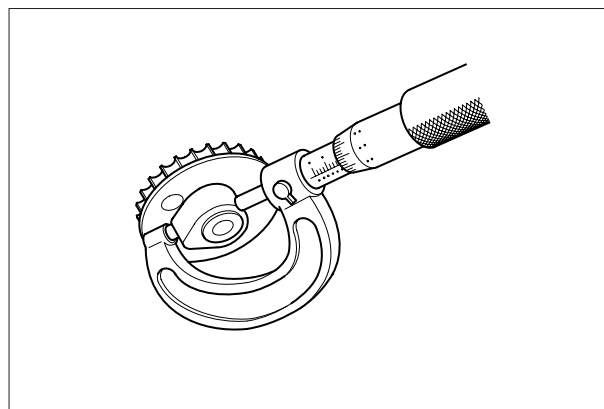

**• CAM PULLEY SHAFT O.D.**

Standard	Service limit
3.990 – 4.000 mm (0.1571 – 0.1575 in)	3.950 mm (0.1555 in)

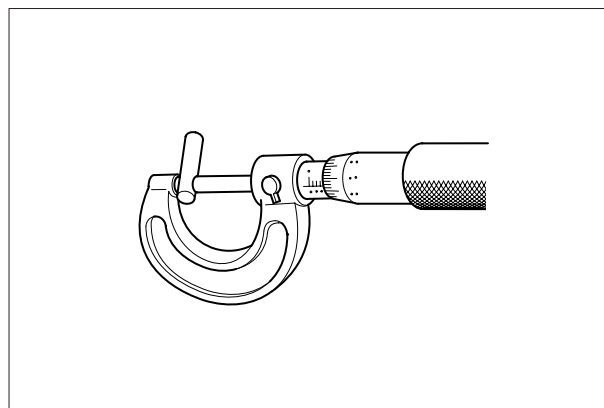

**• CAM PULLEY I.D.**

Standard	Service limit
4.020 – 4.070 mm (0.1583 – 0.1602 in)	4.100 mm (0.1614 in)

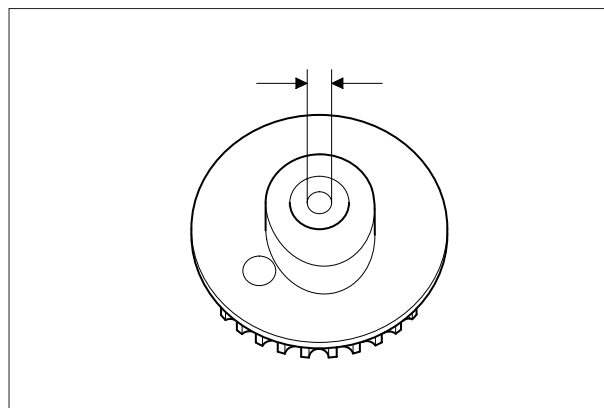

**• VALVE SPRING FREE LENGTH**

Measure the free length of the valve spring.

Standard	Service limit
21.77 mm (0.8570 in)	21.00 mm (0.8268 in)

Replace the springs if they are shorter than the service limit.

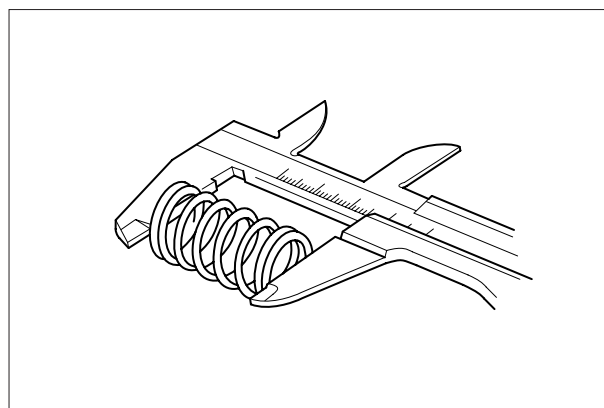

## • VALVE FACE/STEM O.D.

Inspect each valve for pitting or wear irregularities.  
Inspect each valve stem for bending or abnormal stem wear.  
Replace the valve if necessary.

Measure and record each valve stem O.D.

	Standard	Service limit
IN	3.470 – 3.485 mm (0.1366 – 0.1372 in)	3.400 mm (0.1339 in)
EX	3.435 – 3.450 mm (0.1352 – 0.1358 in)	3.380 mm (0.1331 in)

Replace the valves if their O.D. is smaller than the service limit.

## • VALVE GUIDE I.D.

Measure and record each valve guide I.D.

Standard	Service limit
3.500 – 3.518 mm (0.1378 – 0.1385 in)	3.560 mm (0.1402 in)

Replace the cylinder block if the measurement exceeds the service limit.

## • VALVE STEM-TO-GUIDE CLEARANCE

Subtract each valve stem O.D. from the corresponding guide I.D. to obtain the stem-to-guide clearance.

	Standard	Service limit
IN	0.015 – 0.048 mm (0.0006 – 0.0019 in)	0.098 mm (0.0039 in)
EX	0.050 – 0.083 mm (0.0020 – 0.0033 in)	0.120 mm (0.0047 in)

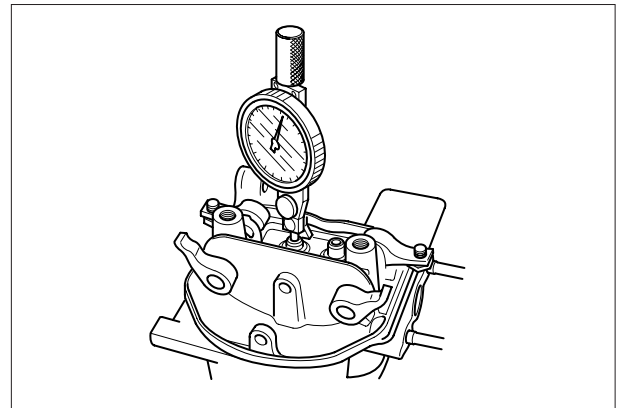
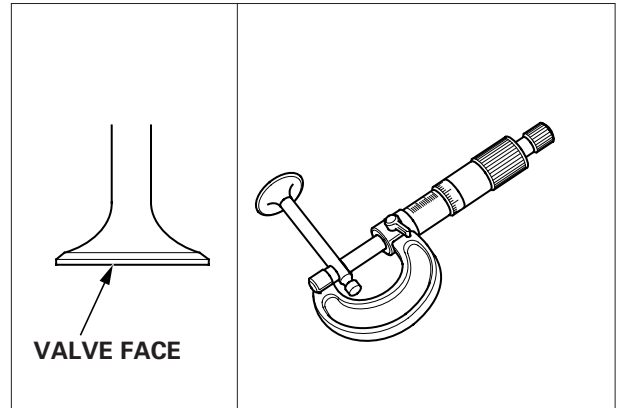

## • CYLINDER BLOCK

### COMBUSTION CHAMBER CLEANING:

- 1) Prepare a cylinder of thick paper or equivalent material, with a diameter large enough to fit against the inner wall of the cylinder, and insert it into the cylinder for protection.
- 2) Attach a commercially available cleaning brush to an electric drill and clean the combustion chamber.

#### NOTICE

To avoid damaging the cylinder block:

- Clean the combustion chamber with the valves installed in the cylinder block.
- Be sure to insert thick paper into the cylinder to protect the inner wall of the cylinder during cleaning of the combustion chamber.
- Do not press the cleaning brush with force against the combustion chamber.

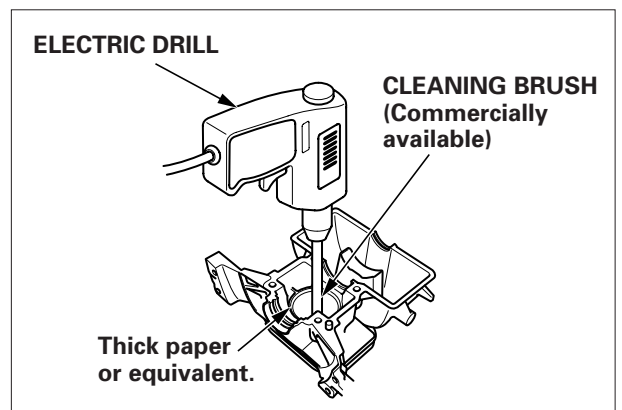

## 4. ROCKER ARM/VALVE LIFTER

### REMOVAL

1. Remove the adjusting screw lock nuts [1] and remove the adjusting screws [2] from the rocker arms [3].

Remove the cam pulley (P. 8-1).

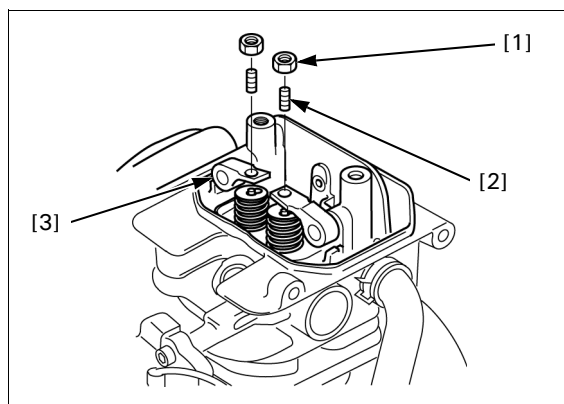

2. Tighten the holder bolt [1] of the special tool fully as shown.

#### TOOL:

**Rocker arm replacement tool [2] 070PF-Z0HA100**

Set the special tool on the cylinder head over the rocker arm and valve lifter that you are going to take apart, and tighten the bolt (5 mm) [3] to the cylinder head cover installation boss [4] by hand.

Do not tighten the bolt (5 mm) using a wrench.

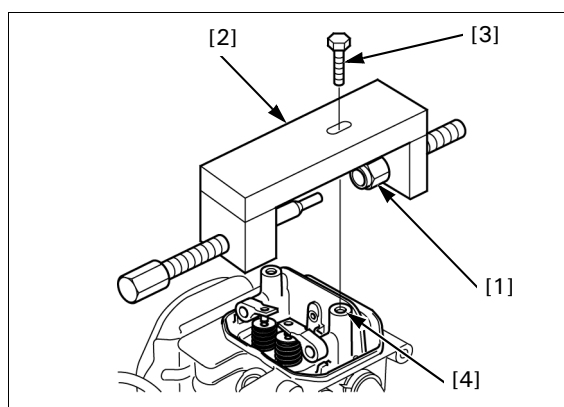

3. Tighten the push rod [1] of the special tool by hand until the tip of the push rod comes to the center of the valve lifter shaft [2]. Move the special tool left and right and check that it can be moved slightly.

It should be able to move slightly in this direction.  
(Or the cylinder head cover installation boss will be damaged)

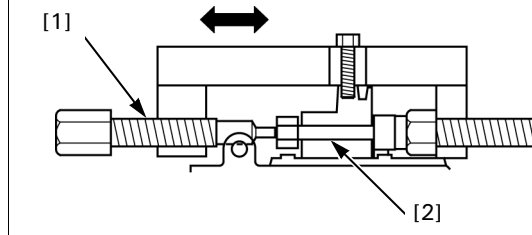

4. Using a 14 mm wrench [1], tighten the push rod [2] until the shaft of the valve lifter goes out from the rocker arm [3].

Loosen the push rod and remove the bolt (5 mm) [4], and then remove the special tool.

The valve lifters and rocker arms cannot be reused after they are pressed apart. Always replace with new parts.

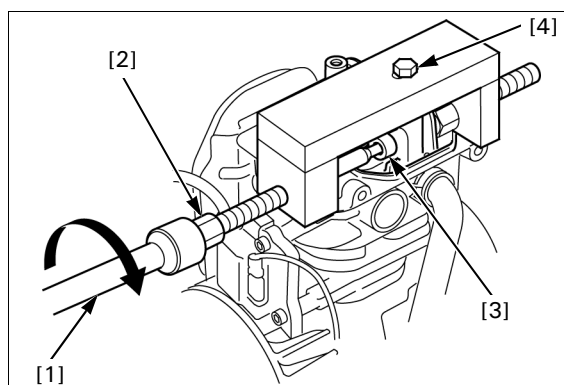

## INSTALLATION

1. Install the new valve lifter [1] on the cylinder head and bring the valve lifter in contact with the installation guide rib [2] of the cylinder head.

Push the new rocker arm [3] into the shaft of the valve lifter by hand while holding the valve lifter in the position and holding the rocker arm against the installation guide rib [4] of the cylinder head.

- Check the valve lifter for inlet side and exhaust side before installation. Do not interchange them.
- Check the rocker arm for "IN" or "EX" marks before installation. Do not interchange them.

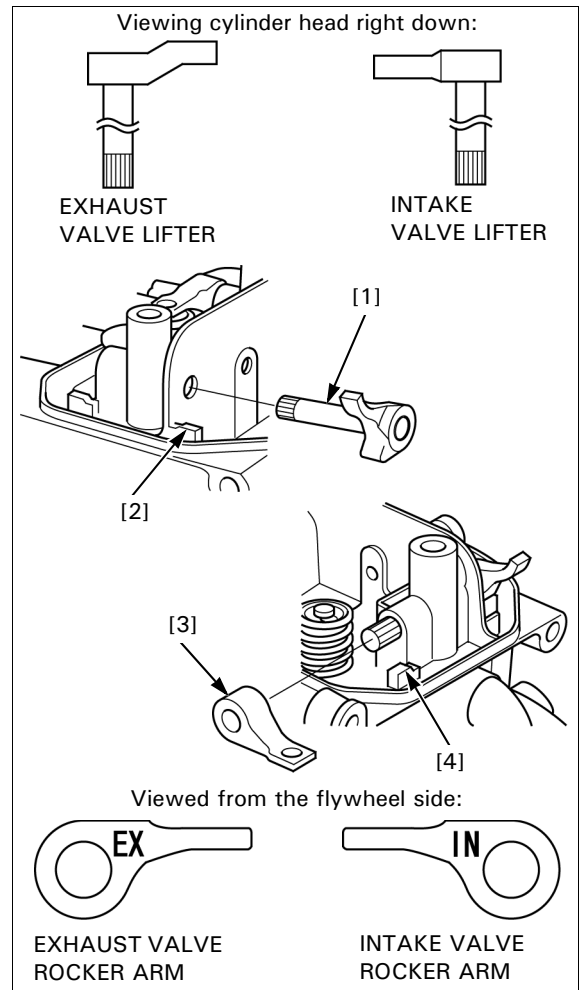

2. Set the projection [1] of the valve lifter [2] in contact with the installation guide rib [3] of the cylinder head.

Set the rocker arm [4] in contact with the installation guide rib [5] of the cylinder head.

Check that the projection on the valve lifter and the rocker arm are in contact with the installation guide rib of the cylinder head.

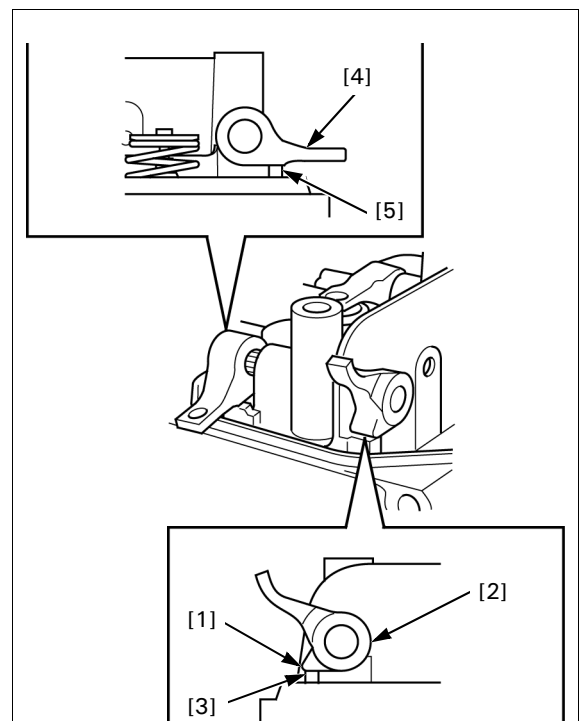

3. Install the holder bolt [1] of the special tool in the direction as shown.

**TOOL:**

**Rocker arm replacement tool [2]**

**070PF-ZOHA100**

Install the adapter [3] on the tip of the push rod [4] that is set on the special tool.

Install the special tool on the cylinder head so that the bolt (5 mm) [5] sets in the center of the long hole in the special tool as shown.

Tighten the bolt (5 mm) against the cylinder head cover mounting boss by hand.

- Set the bolt (5 mm) in the center of the long hole.
- Do not tighten the bolt (5 mm) using a wrench.

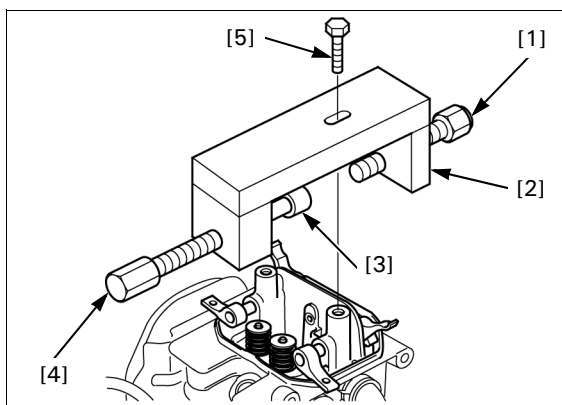

4. Bring the projection on the valve lifter [1] and the rocker arm [2] to come in contact with the cylinder head positioning ribs [3].

Bring the clearance A [4] and B [5] to be equal by moving the valve lifter and rocker arm right and left.

While holding the valve lifter and rocker arm in the position, tighten the holder bolt [6] by hand until it contacts the valve lifter. Tighten the push rod [7] by hand until the adapter [8] contacts the rocker arm.

After installing the special tool, check that the bolt (5 mm) [9] is in the center of the long hole [10] in the tool.

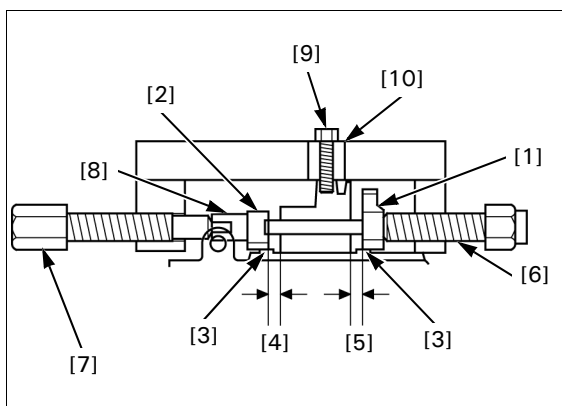

**NOTICE**

*The cylinder head cover mounting boss can be damaged by tightening the push rod with the bolt (5 mm) not in the center but on either side in the long hole. Be sure that the bolt is in the center of the long hole securely.*

5. Using a 14 mm wrench [1], tighten the push rod [2] until the rocker arm [3] comes to the cylinder head cover installation part. [4]

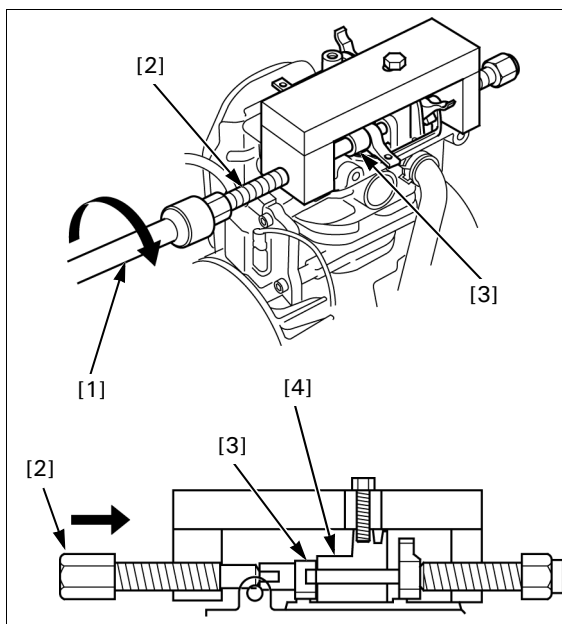



- Loosen the push rod [1] and tighten the holder bolt [2] by hand until the valve lifter [3] contacts the cylinder head cover mounting boss [4]. Be sure that the bolt (5 mm) [5] is in the center of the long hole in the special tool.

**NOTICE**

*The cylinder head cover mounting boss can be damaged by tighten the push rod with the bolt (5 mm) not in the center but on either side in the long hole. Be sure that the bolt is in the center of the long hole securely.*

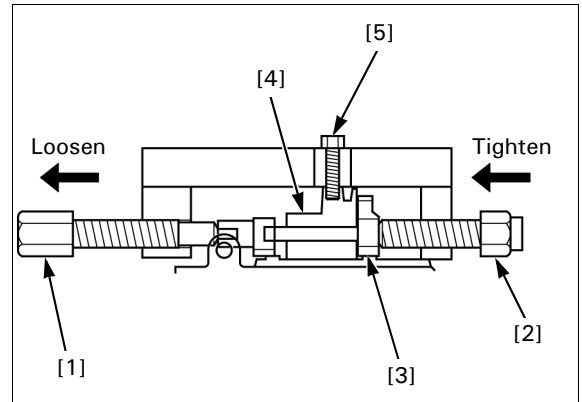

- Using a 14 mm wrench, retighten the push rod [1] until the adapter [2] comes to the shaft of the valve lifter [3]. Loosen the push rod and remove the bolt (5 mm) [4], and then remove the special tool.

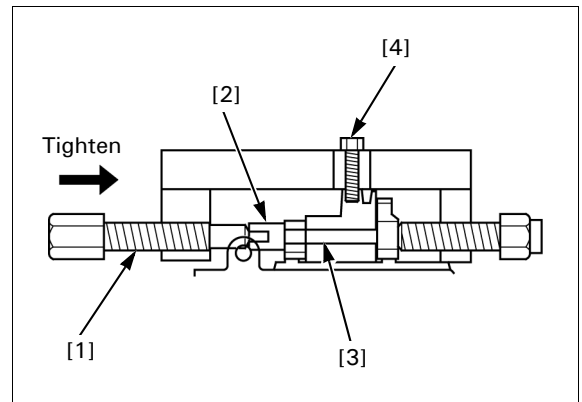

- Measure the clearance between the rocker arm and the cylinder head, and make sure if the clearance are within the specification.

**Rocker arm and cylinder head clearance:**  
**0.15 – 0.65 mm (0.006 – 0.026 in)**

If the clearance is over the specification, the rocker arm is not correctly installed to the valve lifter. Install the special tool again, and tighten the push rod until the rocker arm is completely pressed onto the shaft of the valve lifter.

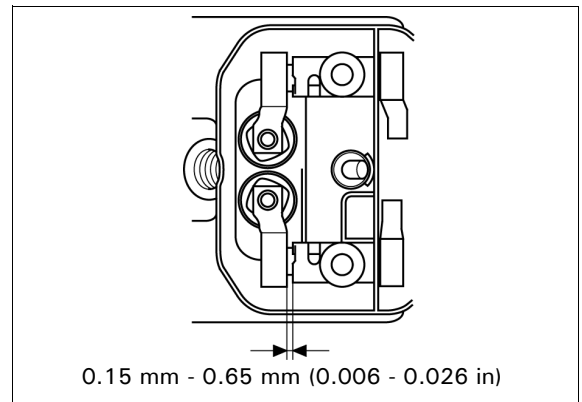

- Inject the oil as shown. Lift the lifter with your finger, release it, and make sure it operates by the lifter's weight.

Install the adjusting screws and the adjusting screw lock nuts to the rocker arms.

Install the cam pulley (P. 8-1).

Adjust the valve clearance (P. 3-4).

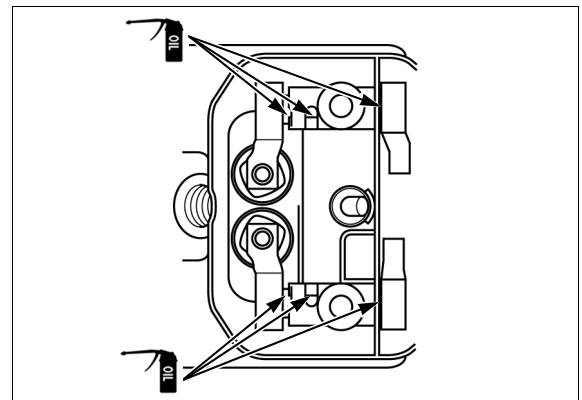

AIR CLEANER		
CLEANING.....	3-3	
REMOVAL/INSTALLATION.....	5-1	
CAM PULLEY.....	8-1	
CARBURETOR		
ADJUSTMENT.....	3-5	
REMOVAL/INSTALLATION.....	5-2	
DISASSEMBLY/REASSEMBLY.....	5-3	
CLUTCH SHOE.....	7-2	
CRANKSHAFT.....	9-1	
CYLINDER BLOCK.....	9-5	
CYLINDER HEAD COVER.....	8-1	
DIMENSIONAL DRAWINGS.....	1-3	
ENGINE OIL.....	3-2	
FLYWHEEL.....	7-2	
FUEL FILTER.....	3-5	
FUEL TANK		
CLEANING.....	3-5	
REMOVAL/INSTALLATION.....	6-4	
FUEL TANK PROTECTOR.....	6-4	
IGNITION COIL.....	7-2	
INSPECTION		
CAM PULLEY.....	9-8	
CLUTCH ASSEMBLY.....	7-4	
CONNECTING ROD.....	9-7	
CRANKSHAFT.....	9-4	
CYLINDER.....	9-6	
CYLINDER BLOCK.....	9-9	
CYLINDER HEAD INNER COVER.....	8-3	
IGNITION COIL.....	7-4	
PISTON.....	9-6	
PISTON PIN.....	9-7	
PISTON RING.....	9-6	
VALVE.....	9-9	
VALVE SPRING.....	9-8	
LOWER CRANKCASE.....	8-4	
MAINTENANCE SCHEDULE.....	3-1	
MAINTENANCE STANDARDS.....	2-2	
MUFFLER.....	4-1	
PERFORMANCE CURVES.....	1-2	
PISTON.....	9-1	
RECOIL STARTER.....	6-1	
SERIAL NUMBER LOCATIONS.....	2-1	
SPARK ARRESTER.....	3-6	
SPARK PLUG.....	3-3	
SPECIAL TOOLS.....	2-4	
SPECIFICATIONS.....	1-1	
STARTER PULLEY.....	7-1	
SYMBOLS USED IN THIS MANUAL.....	2-1	
TOP COVER.....	4-1	
TORQUE VALUES.....	2-3	
TROUBLESHOOTING.....	2-5	
VALVE CLEARANCE.....	3-4	
VALVES.....	9-5	
WIRING DIAGRAM.....	1-4	

**HONDA**

**SHOP  
MANUAL**

**GX35NT  
ENGINE**

**Supplement Z**  
to the  
**GX35 Shop Manual**

---

# A Few Words About Safety

## SERVICE INFORMATION

The service and repair information contained in this manual is intended for use by qualified, professional technicians. Attempting service or repairs without the proper training, tools, and equipment could cause injury to you and/or others. It could also damage this Honda product or create an unsafe condition.

This manual describes the proper methods and procedures for performing service, maintenance, and repairs. Some procedures require the use of special tools. Any person who intends to use a replacement part, service procedure, or a tool that is not recommended by Honda must determine the risks to his or her personal safety and the safe operation of this product.

If you need to replace a part, use Honda Genuine parts with the correct part number or an equivalent part. We strongly recommend that you do not use replacement parts of inferior quality.

## For Your Customer's Safety

Proper service and maintenance are essential to the customer's safety and the reliability of this product. Any error or oversight while servicing this product can result in faulty operation, damage to the product, or injury to others.

### **⚠ WARNING**

**Improper service or repairs can create an unsafe condition that can cause your customer or others to be seriously hurt or killed.**

**Follow the procedures and precautions in this manual and other service materials carefully.**

## For Your Safety

Because this manual is intended for the professional service technician, we do not provide warnings about many basic shop safety practices (Hot parts-wear gloves, for example). If you have not received shop safety training or do not feel confident about your knowledge of safe servicing practice, we recommend that you do not attempt to perform the procedures described in this manual.

Some of the most important general service safety precautions are given below. However, we cannot warn you of every conceivable hazard that can arise in performing service and repair procedures. Only you can decide whether or not you should perform a given task.

### **⚠ WARNING**

**Failure to properly follow instructions and precautions can cause you to be seriously hurt or killed.**

**Follow the procedures and precautions in this manual carefully.**

## Important Safety Precautions

Make sure you have a clear understanding of all basic shop safety practices and that you are wearing appropriate clothing and using safety equipment. When performing any service task, be especially careful of the following:

- Read all of the instructions before you begin, and make sure you have the tools, the replacement or repair parts, and the skills required to perform the tasks safely and completely.
- Protect your eyes by using proper safety glasses, goggles, or face shields anytime you hammer, drill, grind, or work around pressurized air, pressurized liquids, springs or other stored-energy components. If there is any doubt, put on eye protection.
- Use other protective wear when necessary, for example gloves or safety shoes. Handling hot or sharp parts can cause severe burns or cuts. Before you grab something that looks like it can hurt you, stop and put on gloves.
- Protect yourself and others whenever you have engine-power equipment up in the air. Anytime you lift this product with a hoist, make sure that the hoist hook is securely attached to the product.

Make sure the engine is off before you begin any servicing procedures, unless the instruction tells you to do otherwise. This will help eliminate several potential hazards:

- Carbon monoxide poisoning from engine exhaust. Be sure there is adequate ventilation whenever you run the engine.
- Burns from hot parts. Let the engine and exhaust system cool before working in those areas.
- Injury from moving parts. If the instruction tells you to run the engine, be sure your hands, fingers and clothing are out of the way.

Gasoline vapors and hydrogen gasses from battery are explosive. To reduce the possibility of a fire or explosion, be careful when working around gasoline or batteries.

- Use only a nonflammable solvent, not gasoline, to clean parts.
  - Never store gasoline in an open container.
  - Keep all cigarettes, sparks, and flames away from the battery and all fuel-related parts.
-

**INTRODUCTION**

This manual covers the construction, function and service procedures for the Honda GX35NT engines.

For service information that is not covered in this supplement, refer to the GX35 base shop manual (part number 61Z0Z00).

All information contained in this manual is based on the latest product information available at the time of printing. We reserve the right to make changes at anytime without notice.

No part of this publication may be reproduced, stored in a retrieval system, or transmitted, in any form, by any means, electronic, mechanical, photocopying, recording, or otherwise, without prior written permission of the publisher. This includes text, figures, and tables.

As you read this manual, you will find information that is preceded by a **NOTICE** symbol. The purpose of this message is to help prevent damage to the engine, other property, or the environment.

**SAFETY MESSAGES**

Your safety and the safety of others are very important. To help you make informed decisions, we have provided safety messages and other safety information throughout this manual. Of course, it is not practical or possible to warn you about all the hazards associated with servicing these engine. You must use your own good judgement.

You will find important safety information in a variety of forms, including:

- **Safety Labels** — on the engine.
- **Safety Messages** — Preceded by a safety alert symbol ⚠ and one of three signal words, DANGER, WARNING, or CAUTION.

These signal words mean:

**⚠ DANGER**

You **WILL** be **KILLED** or **SERIOUSLY HURT** if you don't follow instructions.

**⚠ WARNING**

You **CAN** be **KILLED** or **SERIOUSLY HURT** if you don't follow instructions.

**⚠ CAUTION**

You **CAN** be **HURT** if you don't follow instructions.



- **Instructions** — how to service these engines correctly and safely.



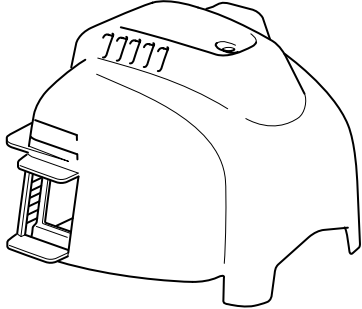

**Honda Motor Co., Ltd.  
Service Publications Office**

**CONTENTS**

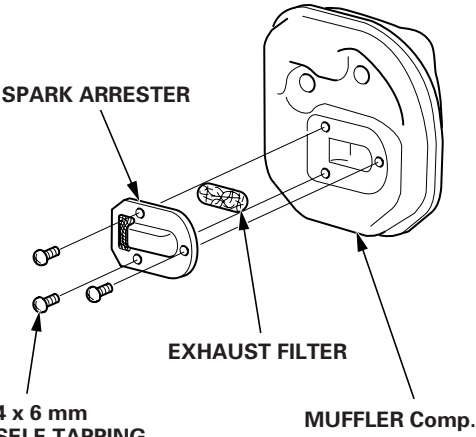
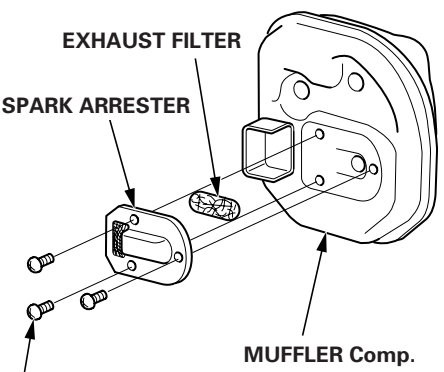
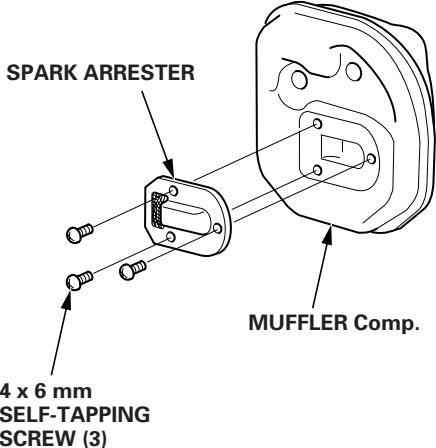
<b>OUTLINE OF CHANGES</b>	
<b>SPECIFICATIONS</b>	<b>1</b>
<b>SERVICE INFORMATION</b>	<b>2</b>
<b>MAINTENANCE</b>	<b>3</b>
<b>TOP COVER/MUFFLER</b>	<b>4</b>
<b>AIR CLEANER/CARBURETOR</b>	<b>5</b>
<b>RECOIL STARTER/FUEL TANK</b>	<b>6</b>
<b>STARTER PULLEY/IGNITION COIL/ CLUTCH SHOE/FLYWHEEL</b>	<b>7</b>
<b>CAM PULLEY/CYLINDER HEAD COVER/ LOWER CRANKCASE</b>	<b>8</b>
<b>CRANKSHAFT/PISTON/CYLINDER BARREL/VALVES</b>	<b>9</b>
<b>INDEX</b>	<b>10</b>

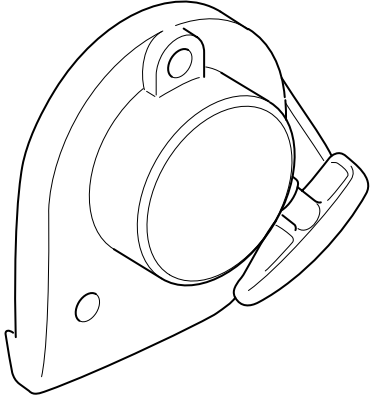
■ The marked sections contain no changes. They are not covered in this manual.

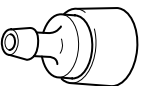
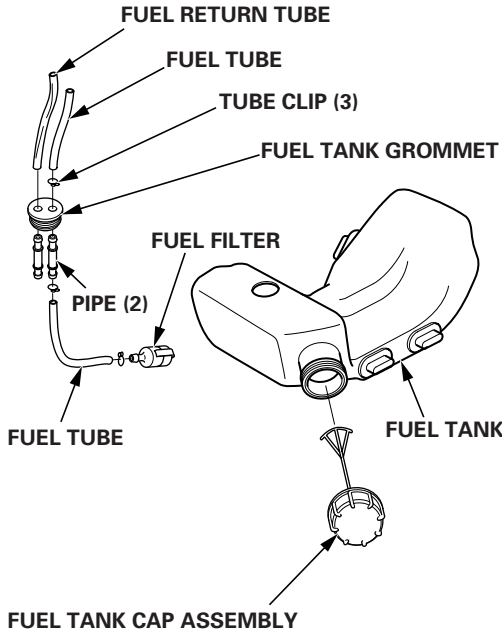
Item	GX35NT	GX35
Top cover (Vertical types only)		
Muffler	<p><b>Horizontal types:</b></p>  <p><b>Vertical types:</b></p> 	

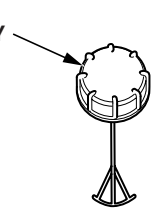
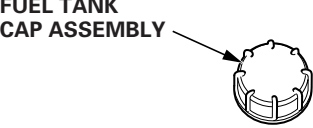
Item	GX35NT	GX35
Recoil starter assembly (Back side pull type)		
Fuel filter		
Fuel tank (Vertical types only)		
Fuel tank cap assembly		

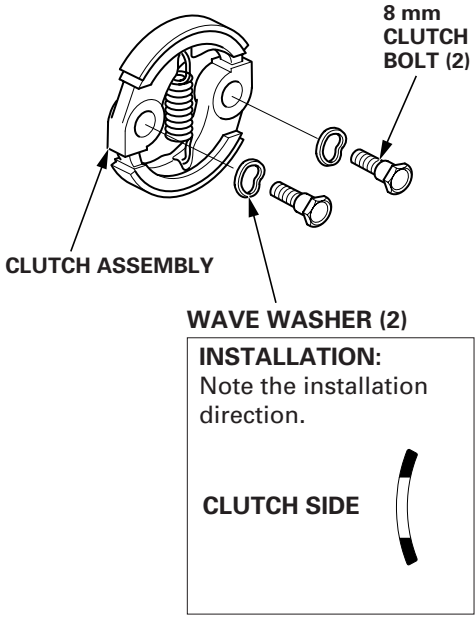
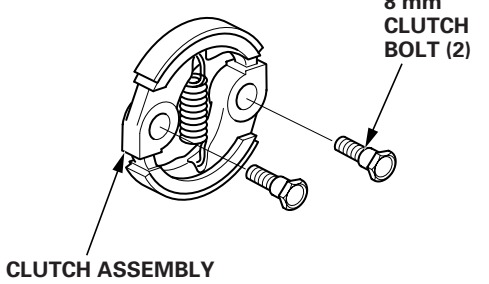
Item	GX35NT	GX35
Wave washer	 <p><b>CLUTCH ASSEMBLY</b></p> <p><b>8 mm CLUTCH BOLT (2)</b></p> <p><b>WAVE WASHER (2)</b></p> <p><b>INSTALLATION:</b> Note the installation direction.</p> <p><b>CLUTCH SIDE</b></p>	 <p><b>CLUTCH ASSEMBLY</b></p> <p><b>8 mm CLUTCH BOLT (2)</b></p>



<b>1. SPECIFICATIONS</b>	<b>2. DIMENSIONAL DRAWINGS</b>
--------------------------	--------------------------------

# 1. SPECIFICATIONS

## • DIMENSIONS AND WEIGHTS

Model	GX35NT
Overall length*1	198 mm (7.8 in)
Overall width*3	234 mm (9.2 in)
Overall height*2	240 mm (9.4 in)
Dry weight*1	3.33 kg (7.34 lbs)
Operating weight*1	3.88 kg (8.55 lbs)

\*1: Without the clutch

\*2: For the fuel tank protector equipped type, refer to page 1-2

\*3: For the vertical type, refer to page 1-2

## • ENGINE

Model	GX35NT
Description code	GCAST
Type	4-stroke, overhead cam, single cylinder
Displacement	35.8 cm <sup>3</sup> (2.18 cu-in)
Bore x stroke	39.0 x 30.0 mm (1.54 x 1.18 in)
Net power*	1.0 kW (1.3 hp) at 7,000 rpm
Max net torque*	1.6 N•m (1.2 lbf•ft) at 5,500 rpm
Compression ratio	8.0 : 1
Fuel consumption	0.71 ℓ/hr at 7,000 rpm
Cooling system	Forced air
Ignition system	Transistorized magneto ignition
Ignition timing	27° B.T.D.C. (Fixed)
Spark plug	CMR5H (NGK)
Carburetor	Diaphragm type
Air cleaner	Semi-dry type
Lubrication system	Oil mist
Oil capacity	100 cc (3.4 US oz, 3.5 Imp oz)
Recommended operating ambient temperature	-5°C ~ 40°C (23°F ~ 104°F)
Starting system	Recoil starter
Stopping system	Ignition primary circuit ground
Fuel used	Unleaded gasoline with a pump octane rating of 86 or higher
Fuel capacity	0.63 ℓ (0.17 US gal, 0.14 Imp gal) (pre-2010 year)
	0.63 ℓ (0.17 US gal, 0.14 Imp gal) (low-perm, horizontal type) (Serial # GSAST-1110538 ~ 1110651, 1114891 and later)
	0.64 ℓ (0.17 US gal, 0.14 Imp gal) (low perm, vertical type) (Serial # GSAST-1116491 and later)
PTO shaft rotation	Counterclockwise (from the PTO shaft side)

\* The power rating of the engine indicated in this document is the net power output tested on a production engine for the engine model and measured in accordance with SAE J1349 at 7,000 rpm (Net power) and at 5,000 rpm (Max net torque). Mass production engines may vary from this value. Actual power output for the engine installed in the final machine will vary depending on numerous factors, including the operating speed of the engine in application, environmental conditions, maintenance, and other variables.

## 2. DIMENSIONAL DRAWINGS

Unit: mm (in)

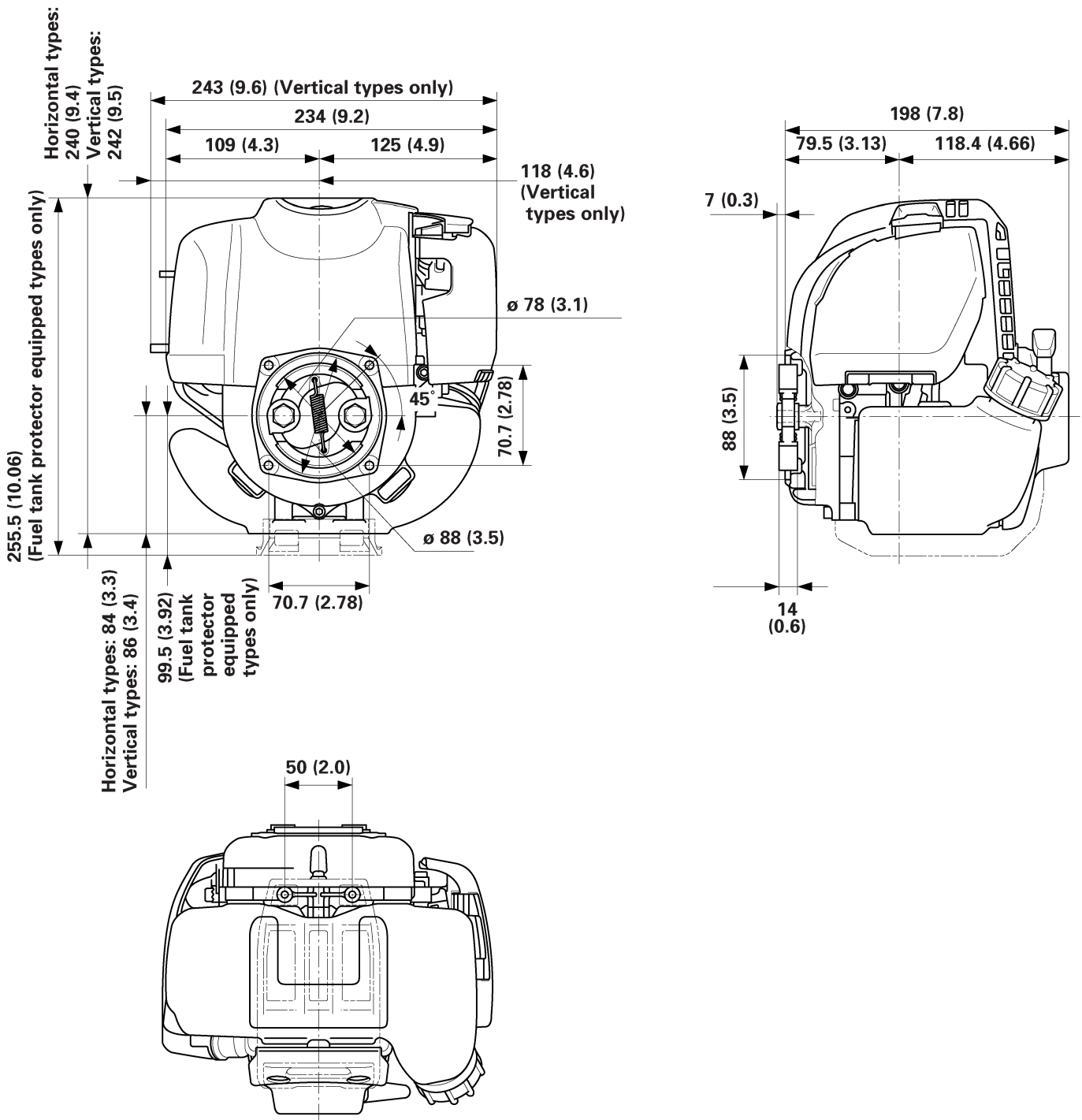

## 1. MAINTENANCE STANDARDS

## 2. TORQUE VALUES

## 1. MAINTENANCE STANDARDS

Unit: mm (in)

Part	Item	Standard	Service Limit
Engine	Cylinder Compression	1.06 MPa (10.8 kgf/cm <sup>2</sup> , 154 psi) at 2,000 min <sup>-1</sup> (rpm)	—
Carburetor	Main jet	#35 (Vertical types) #37 (Horizontal types)	—

## 2. TORQUE VALUES

Item	Thread dia. (mm)	Torque values		
		N·m	kgf·m	lbf·ft
Lower crankcase	M5 (CT)	6.4	0.65	4.7
Fan cover	M5 (CT)	6.4	0.65	4.7
Reed valve plate	M4	3.0	0.31	2.2
Ignition coil	M4	3.4	0.35	2.5
Recoil starter pulley	M6	6.4	0.65	4.7
Flywheel	M8	22.6	2.30	16.7
Valve adjusting screw lock nut	M5	4.9	0.50	3.6
Spark plug	M10	11.8	1.20	8.7
Top cover	M5	3.0	0.31	2.2
Clutch bolt	M8	15.2	1.55	11.2
Muffler	M5	6.4	0.65	4.7
	M5 (STUD BOLT)	4.4	0.45	3.2
Air cleaner case nut	M5	4.9	0.50	3.6

## NOTE:

- CT (Cutting Thread) indicates a self-tapping bolt.
- Use standard torque values for fasteners that are not listed in this table.

**• STANDARD TORQUE VALUES**

Item	Thread Dia.	Torque values		
		N·m	kgf·m	lbf·ft
Screw	3 mm	1.0	0.10	0.7
	4 mm	2.1	0.21	1.5
Bolt and nut	4 mm	3.4	0.35	2.5
	5 mm	5.4	0.55	4.0
	6 mm	9.8	1.00	7.2
CT flange bolt	5 mm	5.9	0.60	4.4

**1. MAINTENANCE SCHEDULE**

## 1. MAINTENANCE SCHEDULE

REGULAR SERVICE PERIOD (2)		each use	First month or 10 Hrs.	Every 3 months or 25 Hrs.	Every 6 months or 50 Hrs.	Every year or 100 Hrs.	Every 2 years or 300 Hrs.	Refer to page	
ITEM	Perform at every indicated month or operating hour interval, whichever comes first.								
Engine oil	Check level	○						*P. 3-2	
	Change		○		○				
Air cleaner	Check	○						*P. 3-3	
	Clean			○ (1)					
Spark plug	Check-adjust					○		*P. 3-3	
	Replace						○		
Spark arrester	Clean					○		*P. 3-6	
Exhaust filter	Clean					○		P. 4-1	
Engine cooling fins	Check				○			—	
Nuts, bolts, fasteners (Retighten if necessary)	Check	○						—	
Clutch assembly	Check				○			*P. 7-4	
Idle speed	Check-adjust					○		*P. 3-5	
Valve clearance	Check-adjust					○		*P. 3-4	
Combustion chamber	Clean		After every 300 hrs						—
Fuel filter	Check					○		*P. 3-5	
Fuel tank	Clean					○		*P. 3-5	
Fuel tubes	Check		Every 2 years (Replace if necessary)						*P. 6-4
Oil tube	Check		Every 2 years (Replace if necessary)						—

(1) Service more frequently when used in dusty areas.

(2) For commercial use, log hours of operation to determine proper maintenance intervals.

\*: Refer to the base shop manual.

**1. TOP COVER/MUFFLER**

## 1. TOP COVER/MUFFLER

### a. REMOVAL/INSTALLATION

#### ⚠ CAUTION

The engine and muffler become very hot during operation and they remain hot for a while after operation. Be sure that the engine is cold before muffler removal/installation.

#### MUFFLER Comp.

##### REASSEMBLY:

- Use a plastic hammer to remove any carbon deposits from the muffler.
- Do not tap on the muffler seal flange or mounting flange to avoid damaging these parts. If the seal flange or mounting flange is dented or damaged, replace the muffler.
- Check the cylinder exhaust port for carbon buildup.

**MUFFLER SEAL FLANGE**

**MOUNTING FLANGE**

Vertical types:

**MUFFLER Comp.**

**5 mm SELF-LOCKING NUT (2)**  
6.4 N·m (0.65 kgf·m, 4.7 lbf·ft)

**4 x 6 mm SELF-TAPPING SCREW (3)**

**UNDER AIR GUIDE Comp.**

**AIR GUIDE**

#### SPARK ARRESTER

**REASSEMBLY:**  
Install after removing the carbon from the screen with a wire brush.

#### EXHAUST FILTER

**CLEANING:**  
Remove any carbon by tapping or squeezing lightly.

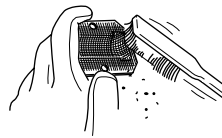
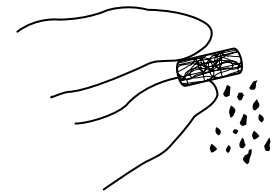

**1. RECOIL STARTER (Back side pull type)**

## 1. RECOIL STARTER (Back side pull type)

### a. DISASSEMBLY

**⚠ CAUTION**  
 The return spring may be ejected from the holder with enough force to injure you.  
 Be sure to release the tension on the return spring before disassembly.

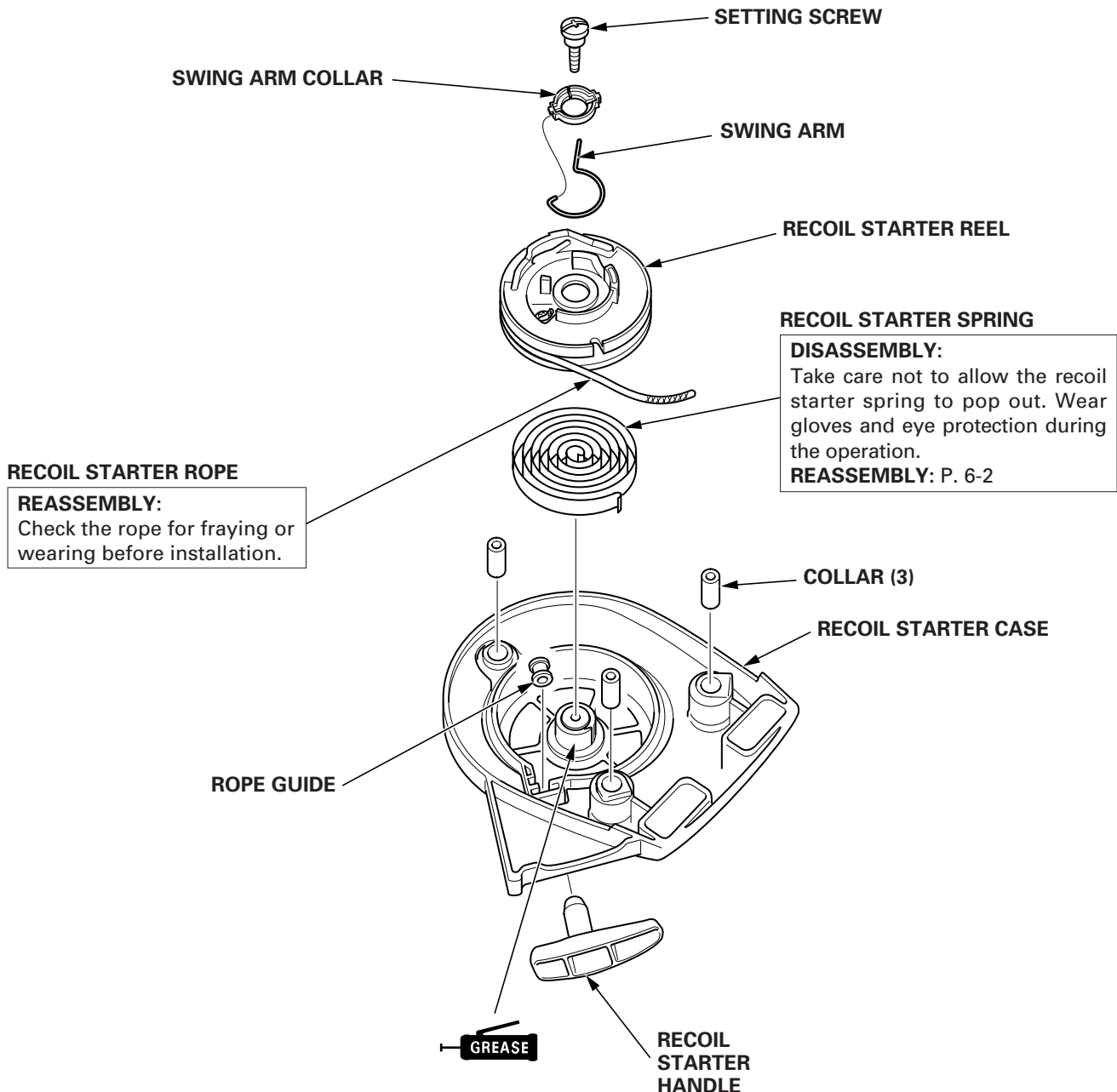

## b. REASSEMBLY

**⚠ CAUTION**

The return spring may be ejected from the holder with enough force to injure you.

Be sure to release the tension on the return spring before disassembly.

- 1) Insert the hook on the outer side of the spring into the groove inside the starter reel. Carefully wind the recoil starter spring inside the starter reel.

- 2) Pass the starter rope through the starter reel and tie the rope so it can be untied easily by pulling it as shown.

Wind the starter rope around the recoil starter reel in the direction of the arrow.

Hook the starter rope into the cutout of the starter reel.

- 3) Install the starter reel on the starter case so the spring inner hook is hooked to the case tab.

- 4) Install the swing arm and swing arm collar to the starter reel as shown.

- 5) Secure the starter reel with the setting screw.

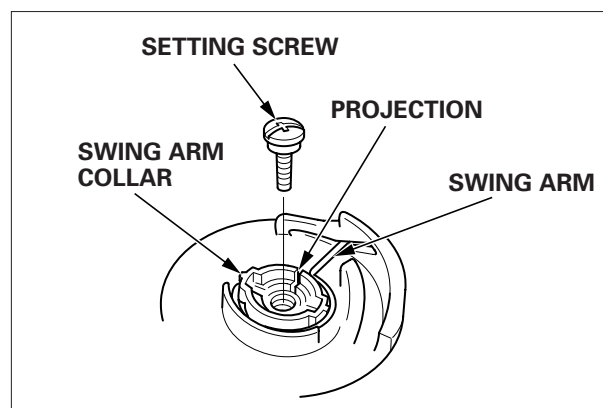
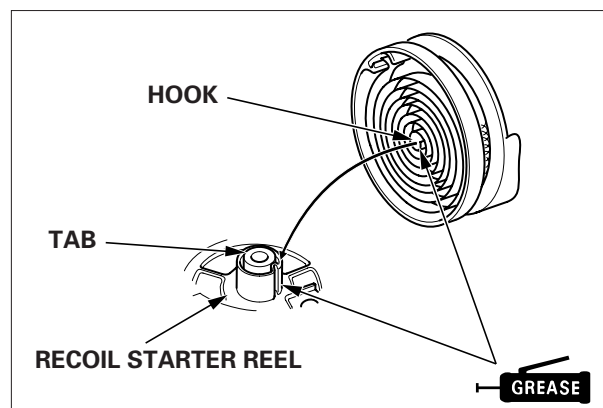
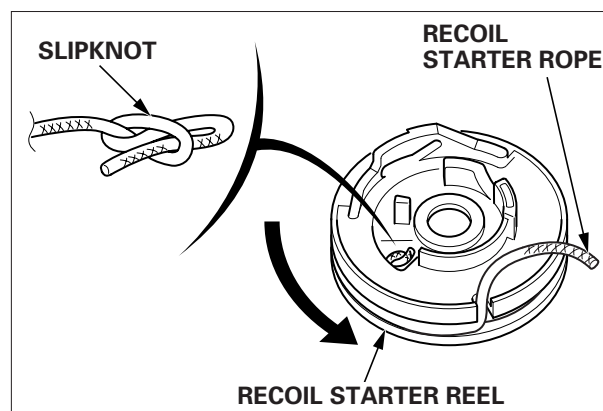
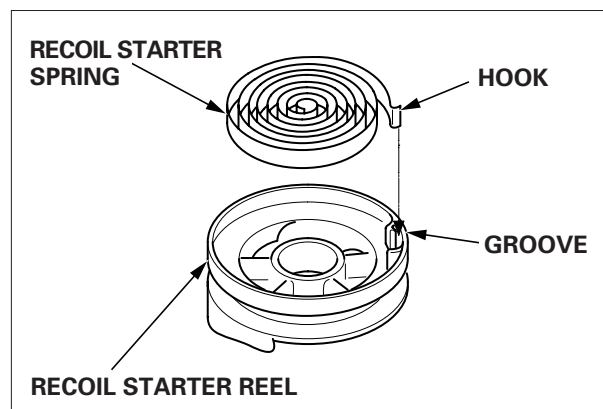



- 6) Hold the starter case and rotate the starter reel three turns in the direction of the arrow for preliminary winding.

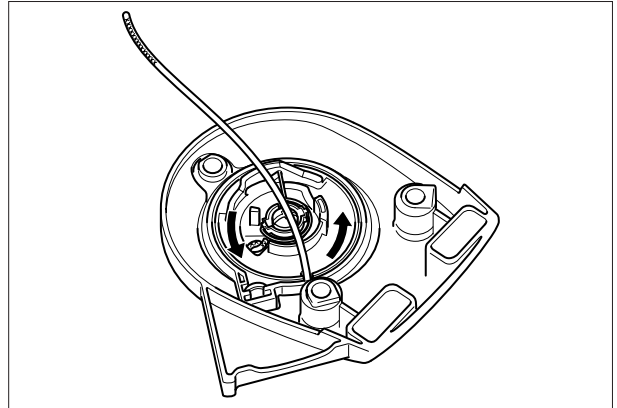

- 7) Unhook the starter rope from the cutout of the starter reel.

Pass the starter rope end through the case and pull it outwards.

Pass the starter rope through the starter handle and tie the rope so it can be untied easily by pulling it as shown.

- 8) Pull the starter handle several times to make sure the swing arm operates properly.

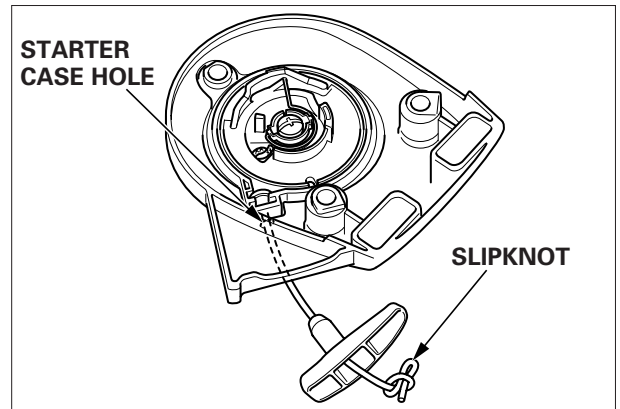

---

DIMENSIONAL DRAWINGS .....	1-2
MAINTENANCE SCHEDULE .....	3-1
MAINTENANCE STANDARDS .....	2-1
MUFFLER .....	4-1
OUTLINE OF CHANGES .....	1
RECOIL STARTER (Back side pull type) .....	6-1
SPECIFICATIONS .....	1-1
TOP COVER .....	4-1
TORQUE VALUES .....	2-1